

SOLUTION
NATIONAL TALENT SEARCH EXAMINATION 2015 Stage-2
MENTAL ABILITY TEST (MAT)

1. If RESPOND is coded as EMPOTDS and SENSE is coded as FRODT, then CLARIFY will be coded as
(1) EDTOJME (2) ZEJSBMD (3) ZEJQBKD (4) ZDKSBKD

Sol. Pattern is +1, -1, +1, -1, +1.....

C L A R I F Y
+1 -1 +1 -1 +1 -1 +1
D K B Q J E Z



Ans. (3) ZEJQBKD

2. Madhu walks 15 metres towards north, then she turns left at 90° and walk 30 metres, then turns right at 90° and walks 25 metres. How far, she is from the starting point and in which direction ?
(1) 55 mt., north-east (2) 50 mt., north-east (3) 60 mt., north (4) 50 mt., west

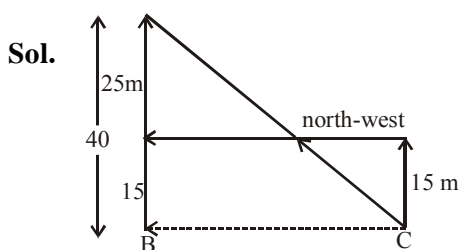

3. Five friends A, B, C, D and E are standing in a row facing south but not necessarily in the same order. Only B is between A and E, C is immediate right to E and, D is immediate left to A. On the basis of above information, which of the following statements is definitely true ?
(1) B is the left of A (2) B is to the right of E
(3) A is second to the left of C (4) D is third to the left of E

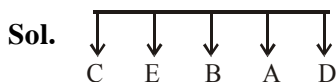

So only option 4 is satisfies.

Directions (Q.4 to Q.8) : A, B, C, E, F, G and H are seven employees in an organisation working in the departments of Administration, Accounts and Operations. There are at least two employees in each department. There are three females, one in each department. Each of seven employees earns different amount. The only bearded employee F works in Administration and his only other colleague G earns the maximum. C, the least earner works in Accounts. B and E are brothers and do not work in the same department. A, husband of H, works in Accounts and earns more than each of F, B and E. The wife in the couple earns more than the husband.

Departments		Income
A	Accounts	More than F,B,E
B	Accounts / Operation	
C	Accounts	Minimum
E	Accounts / Operation	
F	Administration	Maximum
G	Administration	
H		Wife of A

Income : G > H > A > F, B, E > C

SOLUTION
NATIONAL TALENT SEARCH EXAMINATION 2015 Stage-2
MENTAL ABILITY TEST (MAT)

4. Which of the following is a group of females?

- (1) GCE (2) GEH (3) GCH (4) GHB

Sol. Ans. 3, G C H

5. In which department do three people work ?

- (1) Operations (2) Accounts
(3) Operations or Accounts (4) Data inadequate

Sol. Ans. 2, accounts

6. What will be the position of A from the top when they are arranged in descending order of their income ?

- (1) Second (2) Third (3) Fourth (4) Fifth

Sol. Ans. 2, Third

7. In which of the following departments does B work ?

- (1) Operations (2) Accounts (3) Administration (4) Data inadequate

Sol. Ans. 4, Data inadequate

8. Which of the following statements is definitely true ?

- (1) B earns less than F and H (2) F earns more than B and E
(3) B earns more than E and C (4) B earns less than A and H

Sol. Ans. 4, B earns less than A and H.

Directions (Q.9 to Q.11) : Given an input, a machine generates pass codes for the six batches each day as follows:

Input: these icons were taken out from the sea.

Pass Codes

Batch I : from sea the out taken were icons these

Batch II : from icons these were taken out the sea

Batch III : from icons out sea the taken were these

Batch IV : from icons out sea these were taken the

The pattern followed is as under :

In the first step, the word which comes first in the dictionary is placed at the first place and the remaining words are written in a reverse order.

In the second step, the word which comes second in the dictionary is placed at the second place and all words except the first and the second are written in a reverse order. The process continues in the same manner to give the pass codes for the subsequent batches.

9. What will be the pass code for the Batch V on a day, if the input is “four of the following five form a group” ?

- (1) a five following form four group the of (2) a five following form group the of four
(3) a five following form four the of group (4) a five following form four group of the

SOLUTION
NATIONAL TALENT SEARCH EXAMINATION 2015 Stage-2
MENTAL ABILITY TEST (MAT)

Sol. (1) : Input : four of the following five form a group

Batch I (10 a.m. to 11 a.m.) : a group form five following the of four

Batch II (11 a.m. to 12 noon) : a five four of the following form group

Batch III (12 noon to 1 p.m.) : a five following group form the of four

Batch IV(1 p.m. to 2 p.m.) : a five following form four of the group

Rest hour (2 p.m. to 3 p.m.)

Batch V (3 p.m. to 4 p.m.) : a five following form four group the of

10. If the pass code for the Batch IV on a day was 'back go here people who settle want to', what was the pass code for the Batch V on that day?

(1) back go here people settle who want to

(2) back go here people to want settle who

(3) back go here people settle to want who

(4) cannot be determined

Sol. (3) : Clearly. Batch IV starts at 1 p.m. Thus, in the pass code for Batch IV, first four words are arranged in alphabetical order. So, as per the pattern, we ought to place the word which comes fifth in the dictionary at the fifth place and then write all the words except the first five, in reverse order, to get the pass code for the batch at 3.00 p.m., i.e., Batch V.

Batch IV : back go here people who settle want to

Batch V : back go here people settle to want who

11. The pass code for the Batch I on a day was 'he so used to sell the surplus items'. What was input on that day ?

(1) items surplus the sell to used so he

(2) he items surplus the sell to used so

(3) so used to sell the surplus items he

(4) cannot be determined

Sol. (4) : The input may be obtained by writing all words except 'he' in the given pass code in the reverse order and then placing 'he' at any of the eight positions. So, there are eight possible inputs. Thus, it is not possible to determine the exact input.

12. What is the total number of triangles and total numbers of squares in the given figure ?

(1) 28 triangles, 10 squares

(2) 28 triangles, 8 squares

(3) 32 triangles, 10 squares

(4) 32 triangles, 8 squares

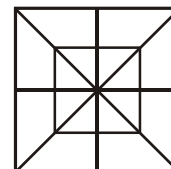

SOLUTION
 NATIONAL TALENT SEARCH EXAMINATION 2015 Stage-2
MENTAL ABILITY TEST (MAT)

Sol. (3) : We may label the figure as shown.

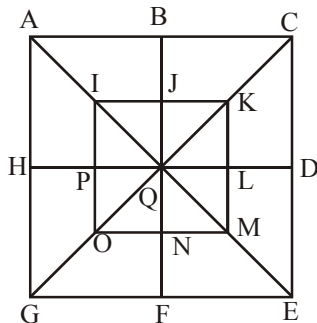

Triangles :

The simplest triangles are IJQ, JKQ, KLQ, LMQ, MNQ, NOQ, OPQ and PIQ i.e. 8 in number.

The triangles composed of two components each are ABQ, BCQ, CDQ, DEQ, EFQ, FGQ, GHQ, HAQ, IKQ, KMQ, MOQ and OIQ i.e. 12 in number.

The triangles composed of four components each are ACQ, CEQ, EGQ, GAQ, IKM, KMO, MOI and OIK i.e. 8 in number.

The triangles composed of eight components each are ACE, CEG, EGA and GAC i.e. 4 in number.

∴ Total number of triangles in the figure = 8 + 12 + 8 + 4 = 32.

Squares :

The squares composed of two components each are IJQP, JKLQ, QLMN and PQNO i.e. 4 in number.

The squares composed of four components each are ABQH, BCDQ, QDEF and HQFG i.e. 4 in number.

There is only one square i.e. IKMO composed of eight components.

There is only one square i.e. ACEG composed of sixteen components

Thus, there are 4 + 4 + 1 + 1 = 10 squares in the given figure.

13. A cube whose two adjacent faces are coloured is cut into 64 identical small cubes. How many of those small cubes are not coloured at all ?

- (1) 24 (2) 32 (3) 36 (4) 48

Sol. Ans. (3)

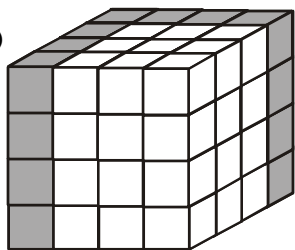

So uncoloured cubes

$$3 \times 3 \times 4 = 36$$

SOLUTION
NATIONAL TALENT SEARCH EXAMINATION 2015 Stage-2
MENTAL ABILITY TEST (MAT)

14. If $54/32 = 4$, $36/42 = 3$, $92/22 = 7$ then what is $28/33 = ?$
 (1) 5 (2) 6 (3) 4 (4) 9

Sol. Ans. (3) $\frac{54}{32} \Rightarrow (5 + 4) - (3 + 2) = 4$

$$\frac{36}{42} \Rightarrow (3 + 6) - (4 + 2) = 3$$

$$\frac{92}{22} \Rightarrow (9 + 2) - (2 + 2) = 7$$

$$\frac{28}{33} \Rightarrow (2 + 8) - (3 + 3) = 4$$

15. In a certain code language, 'po ki top ma' means 'Usha is playing cards'; 'Kop ja ki ma' means 'Asha is playing tennis'; 'ki top sop ho' means 'they are playing football'; and 'po sur kop' means 'cards and tennis'. Which word in this language means 'Asha' ?
 (1) ja (2) ma (3) kop (4) top

Sol. Ans. (1) Po ki top ma → Usha is playing cards.....(i)

Kop ja ki ma → Asha is playing tennis.....(ii)

Ki top sop ho → they are playing football.....(iii)

Po sur kop → cards and tennis.....(iv)

from (i) & (ii) is playing – ki ma

then from (ii) and (iv) – tennis – kop

Remaining code ja stand for Asha

16. A ship navigating in the Indian Ocean is hit by a sea storm and drifts as follows:

40 km North

28 km north-west

36 km west

52 km south and 29 km south east.

The ship had finally drifted in direction from its original position.

- (1) South West (2) South (3) West (4) South East

Sol.

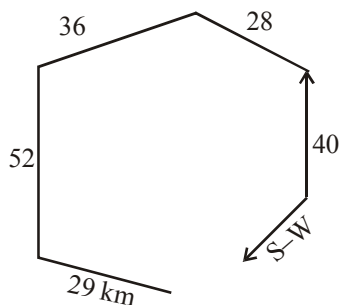

So option (1)

SOLUTION
 NATIONAL TALENT SEARCH EXAMINATION 2015 Stage-2
MENTAL ABILITY TEST (MAT)

17. Four diagrams marked A, B, C and D are given below. The one that best illustrates the relationship among three given classes :

Women, Teachers, Doctors

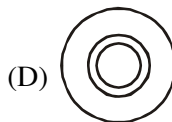
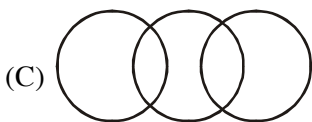
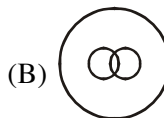
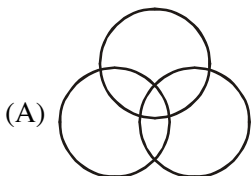

(1) A

(2) B

(3) C

(4) D

Sol.

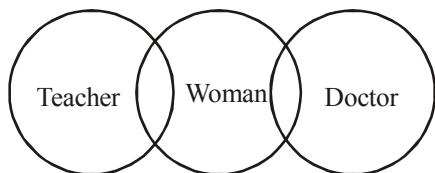

So option 3

18. Identify the missing number in the following sequence

2, 17, 52, _____, 206

(1) 73

(2) 85

(3) 113

(4) 184

Sol. Ans. (3)

2, 17, 52, 113, 206

1^2+1^3 2^3+3^2 3^3+5^2 4^3+7^2 5^3+9^2

19. Select the missing number

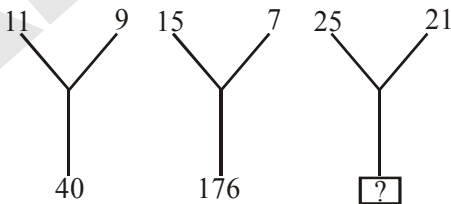

(1) 184

(2) 210

(3) 241

(4) 425

Sol. Ans. (1)

$$(11 + 9) \times (11 - 9) = 40$$

$$(15 + 7) \times (15 - 7) = 176$$

$$(25 + 21) \times (25 - 21) = 184$$

20. Select the missing number in the following sequence

3, 6, 24, 30, 63, 72, ?, ?, 195, 210

(1) 117, 123

(2) 120, 132

(3) 123, 135

(4) 135, 144

SOLUTION
NATIONAL TALENT SEARCH EXAMINATION 2015 Stage-2
MENTAL ABILITY TEST (MAT)

Sol. Ans. (2)

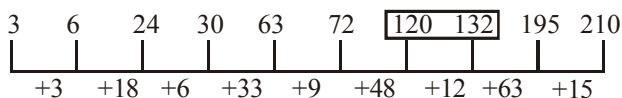

21. Find the number that does not belong to the group :

111, 331, 482, 551, 263, 383, 362, 284

(1) 263

(2) 331

(3) 383

(4) 551

Sol. Ans. (3)

1st digit \times 3rd digit = 2nd digit

So, odd one is 383.

22. Which letter replaces the question mark?

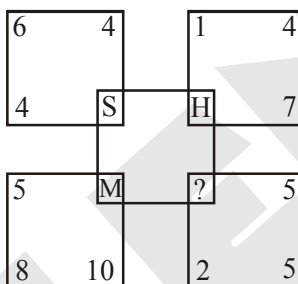

(1) L

(2) N

(3) P

(4) R

Sol. Ans. (2)

$$[36 - (4 \times 4) - 1]$$

$$\Rightarrow 20 - 1 = 19 \Rightarrow S$$

$$[16 - (7 \times 1)] - 1$$

$$\Rightarrow 9 - 1 = 8 \Rightarrow H$$

$$[64 - (10 \times 5)]$$

$$\Rightarrow 14 - 1 = 13 \Rightarrow M$$

In the same way

$$[25 - (5 \times 2)] - 1$$

$$\Rightarrow 15 - 1 = 14 \Rightarrow N \text{ Ans}$$

23. Certain blank spaces are left in the following sequence. Which is the group of letters given below, will complete the sequence ?

c_bba_cab_ac_ab_ac

(1) acbcb

(2) bcacb

(3) babec

(4) abebe

Sol. Ans. (1)

cabbaccabbaccabac

Ans. acbcb

SOLUTION
NATIONAL TALENT SEARCH EXAMINATION 2015 Stage-2
MENTAL ABILITY TEST (MAT)

24. A boat starts with the speed of 1 km per hour. After every 1 km, the speed of boat becomes twice. How much will be the average speed of the boat at the end of journey of 2.5 km?

- (1) $\frac{2.5}{1.5125}$ (2) $\frac{2.5}{1.75}$ (3) $\frac{2.5}{1.625}$ (4) $\frac{2.5}{1.50}$

Sol. Ans. (3)

When the speed of boat increases time will decrease due to inverse relations.

So in first 1 km speed is 1 km/hr

in second 1 km speed is 2 km/hr

in last 5 km speed is 4 km/hr

So time in first 1km is 1hr

in second 1km is $\frac{1}{2}$ hr

in last 5 km is $\frac{1}{4}$ hr

So total times 1.75 hr

So average speed = $\frac{\text{total distance}}{\text{total time}}$

$$= \frac{2.5}{\frac{1}{1} + \frac{1}{2} + \frac{0.5}{4}} = \frac{2.5}{1.625}$$

25. Using the total number of alphabets in your solution as a parameter, find the number that represents G is.

A - 0, B - 0, C - 2, D - 2, E, - 1, F - 2 G - ?

- (1) 2 (2) 3 (3) 4 (4) 5

Sol. $\frac{\text{Total no. of alphabets (26)}}{\text{position value of alphabet}} = \text{Reminder}$

$$\frac{26}{G(7)} = \text{Reminder is (5)}$$

So option (4)

26. Rs. 1000 is given to A, B and C in some ratio. A is wrongly given double and C is wrongly given half, which is Rs. 500 and Rs. 250 respectively. How much is given to B ?

- (1) 500 (2) 250 (3) 750 (4) None of above

Sol. A + B + C

$$500 + 250 + 250 = 1000$$

So option (2) B is given 250 Rs.

27. Given that the total cost of 5 erasers, 7 sharpeners and 9 pencils in Rs. 100 and the total cost of 2 erasers 6 sharpeners and 10 pencils is Rs. 80. What is the total cost (in Rs.) of one eraser one sharpener and one pencil ?

- (1) 10 (2) 15 (3) 20 (4) Data not sufficient

SOLUTION
NATIONAL TALENT SEARCH EXAMINATION 2015 Stage-2
MENTAL ABILITY TEST (MAT)

Sol. Ans. (2)

$$5e + 7s + 9p = 100 \dots (i)$$

$$2e + 6s + 10p = 80 \dots (ii)$$

Subtract (ii) from (i)

$$3e + s - p = 20 \dots (iii)$$

Add (i) in (ii)

$$8e + 8s + 8p = 120$$

$$\text{So, } e + s + p = 15$$

28. Renu went to the market between 7 am and 8 am. The angle between the hour-hand and the minute-hand was 90° . She returned home between 7 am and 8 am. Then also the angle between the minute-hand and hour-hand was 90° . At what time (nearest to second) did Renu leave and return home ?

(1) 7 h 18 m 35 s and 7 h 51 m 24 s

(2) 7 h 19 m 24 s and 7 h 52 m 14 s

(3) 7 h 20 m 42 s and 7 h 53 m 11 s

(4) 7 h 21 m 49 s and 7 h 54 m 33 s

Sol. Between 7 am to 8 am

Right angles are

$$1^{\text{st}} \rightarrow \frac{12}{11} \times 20 = \frac{240}{11} = 21 \text{ m } 49 \text{ s}$$

$$2^{\text{nd}} \rightarrow \frac{12}{11} \times 50 = \frac{600}{11} = 54 \text{ m } 33 \text{ s}$$

So, ans is option (4)

29. Stimulant : Activity : : ?

(1) Symptom : Disease

(2) Food : Hunger

(3) Fertilizer : Growth

(4) Diagnosis : Treatment

Sol. Both are synonyms

So in option (3) both are synonyms

30. Choose the missing number from among the four alternatives :

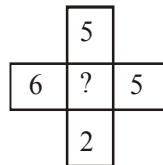
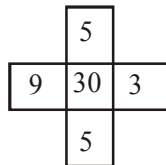
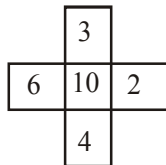

(1) 15

(2) 20

(3) 25

(4) 40

Sol. $6 \times 3 - 4 \times 2 = 10$

$$9 \times 5 - 5 \times 3 = 30$$

$$6 \times 5 - 2 \times 5 = 20$$

So option (2)

SOLUTION
NATIONAL TALENT SEARCH EXAMINATION 2015 Stage-2
MENTAL ABILITY TEST (MAT)

31. From among the four alternatives given below, which number replaces the question mark ?

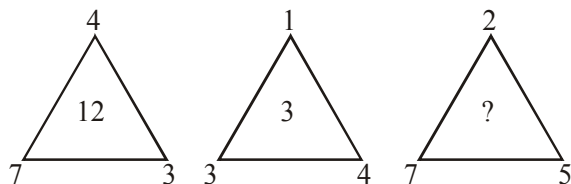

- (1) 9 (2) 10 (3) 18 (4) 23

Sol. $7^2 - (4^2 + 3^2) =$

$$49 - (16 + 9) = \frac{24}{2} = 12$$

$$4^2 - (3^2 + 1^2)$$

$$16 - (9 + 1) = \frac{6}{2} = 3$$

$$7^2 + (5^2 + 2^2)$$

$$49 - (25 + 4) = \frac{20}{2} = 10$$

So, option (2)

32. From among the four alternatives given below, which letter replaces in the given figure the question mark ?

3	P	8
9	G	11
2	U	4
3	W	1
7	?	18

- (1) A (2) B (3) S (4) Y

Sol. Ans. (2)

$$(8 + 3) = 11$$

11th letter from back – P

$$(11 + 9) = 20$$

20th letter from back – G

Same way

$$(18 + 7) = 25$$

25th letter from back – B

33. Choose the correct mirror-image most closely resembles the word source, from the four given alternatives.

source

- (1) ɹoʌɹɹɔɹ (2) ɹɔɹɹɔɹɹ (3) ɹɹɔɹɔɹɹ (4) ɹɹɔɹɔɹ

Sol. (4) ɹɹɔɹɔɹ

SOLUTION
 NATIONAL TALENT SEARCH EXAMINATION 2015 Stage-2
MENTAL ABILITY TEST (MAT)

34. In the problem figure an unfolded cuboid is given. Choose from the four given alternatives the box that will be formed when the problem figure is folded.

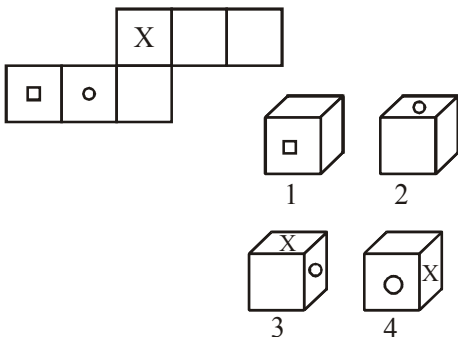

- (1) 1 only (2) 1 and 2 only (3) 1, 2 and 3 only (4) 2 and 3 only

Sol. Only (1) & (2) is possible

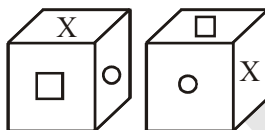

If X is on the top and circle is on right surface then possible diagram is given so here option (3) & (4) are not possible according to the given unfolded structure of the dice.

So option (2)

35. A work can be completed by 40 workers in 40 days. If 5 workers leave every 10 days, in how many days will the work be completed?

- (1) 55.66 (2) 56.44 (3) 56.66 (4) 54.66

Sol. Ans. (3)

Total work is $40 \times 40 = 1600$ units

I. 10 days total work completed

$$= 40 \times 10 = 400$$

II. 10 days total work completed

$$= 35 \times 10 = 350$$

and so on

In 50 days 1500 units of work is done.

Now 15 workers 100 units

So it will be completed in 6.66 days

So total days work will be completed 56.66 days.

36. From among the four alternatives given below, which figure replaces the question mark '?'.

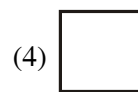
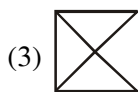
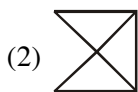
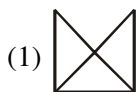

SOLUTION
NATIONAL TALENT SEARCH EXAMINATION 2015 Stage-2
MENTAL ABILITY TEST (MAT)

Sol. Ans. (2)

Number of line increasing in next figure.

37. Six persons A, B, C, D, E and F are sitting in two rows, three persons are sitting in each row

E is not at end of any row

D is second to the left of F

C, the neighbour of E, is sitting diagonally opposite to D

B is the neighbour of F

Who are sitting in each column ?

(1) A and D; E and F; and B and C

(2) A and F; D and E; and B and C

(3) B and D; A and C; and E and F

(4) A and D; B and E; and F and C

Sol. Ans. (4)

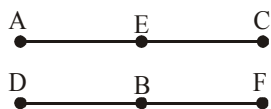

A, D ; E, B & C, F are sitting in each column.

38. The sum of the incomes of A and B is more than that of C and D taken together. The sum of incomes of A and C is the same as that of B and D taken together. Moreover, A earns half as much as the sum of the incomes of B and D. Whose income is the highest ?

(1) A

(2) B

(3) C

(4) D

Sol. $A + B > C + D$

$A + C = B + D$

$$A = \frac{B+D}{2}$$

So the income of C is $\frac{B+D}{2}$

$$\frac{B+D}{2} + B > \frac{B+D}{2} + D$$

$B > D$

So option (2)

39. A letter number series is given with one or more terms missing as shown below. Choose the alternative next in the sequence.

A4X, D9U, G16R,

(1) K25P

(2) J25P

(3) J25O

(4) J25C

Sol. Ans. (3)

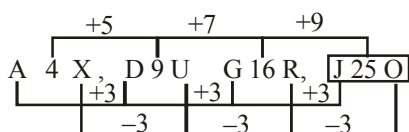

SOLUTION
NATIONAL TALENT SEARCH EXAMINATION 2015 Stage-2
MENTAL ABILITY TEST (MAT)

40. Study the following information and answer the question given below it:

Rohit, Kunal, Ashish and, Ramesh are students of a school. Three of them stay far from the school and one near it. Two studies in class IV, one in class V and one in class VI. They study Hindi, Mathematics, Social Sciences and Science. One is good at all four subjects while another is weak in all of these. Rohit stay far from the school and is good at mathematics only while Kunal is weak in mathematics only and stay close to the school. Neither of these two nor Ashish studies in class VI. One who is good at all the subjects study in class V. Name the boy who is good at all the subjects.

- (1) Rohit (2) Ramesh (3) Kunal (4) Ashish

Sol. Ans. (4)

	Far/Close	Class	Subject
Rohit	far	IV	Good in Maths
Kunal	close	IV	Weak in Maths only
Ashish	far	V	Good in all
Ramesh	far	VI	Weak in all

41. Half of the villagers of a certain village have their own houses. One - fifth of the villagers cultivate paddy. One - third of villagers are literate. Four - fifth of the villagers are below twenty five. Then, which one of the following is certainly true?

- (1) At least 10 percent villagers who have their own houses are literate.
 (2) At least 25 percent of the villagers who have their own houses cultivate paddy.
 (3) At least 50 percent of the villagers who cultivate paddy are below twenty five.
 (4) At least 13.33 percent literate must be below twenty five.

Sol. Ans. (4)

$$\frac{4}{5} \text{ of villager below } 25 = 80\%$$

$$\frac{1}{3} \text{ of villager are literate} = 33.33\%$$

So, min 13.33% of villagers are literate will below 25.

42. A tank is filled by three pipes with each pipe having uniform flow. The first two pipes operating simultaneously fill the tank in the same time during in which the tank is filled by the third pipe alone. The second pipe fills the tank 5 hours faster than the first pipe and 4 hours slower than the third pipe. The time required by the first pipe to fill the tank is:

- (1) 6 hours (2) 10 hours (3) 15 hours (4) 30 hours

SOLUTION
NATIONAL TALENT SEARCH EXAMINATION 2015 Stage-2
MENTAL ABILITY TEST (MAT)

Sol. Ans. (2)

Watch covers 3 min in ____ 60 hrs

Watch covers 1 min in ____ $\frac{60}{3}$ hrs

= 20 hrs

So, 1 pm on tuesday + 20 hrs

= 9 am on wednesday

Directions (Q.45 to Q.47) : A coding language is used to write English words in coded form given below.

TENNIS	% # \$ @ \$ &
TRUE	@ + # *
PRIME	* = ? # %
SPINE	# \$ % ? &

The codes do not appear in the same order of the letters in English words. Decode the language and based on these codes identify the code for English word given in each question from the alternatives provided.

Letter	T	E	S	N	I	P	R	U	M
Coding	@	#	&	\$	%	?	*	+	=

45. MINT

(1) % = & * (2) = # ? % (3) @ % = \$ (4) * @ ? +

Sol. (3)

@ % = \$

46. RINSE

(1) = ? + * @ (2) % * \$ # & (3) * \$ # @ + (4) \$ & # = ?

Sol. (2)

% * \$ # &

47. INTEREST

(1) = ? * + % & = * (2) ? # = ? + # * \$ (3) + \$ @ + \$ = * % (4) @ # * # @ \$ % &

Sol. (4) @ # * # @ \$ % &

Directions (Q.48 to Q.50) : There are three circles in the following diagram. A total number of 100 persons were surveyed and the number in the diagram indicates the number of tourists who visited different states. 46 tourists visited Sikkim and 42 tourists visited Karnataka.

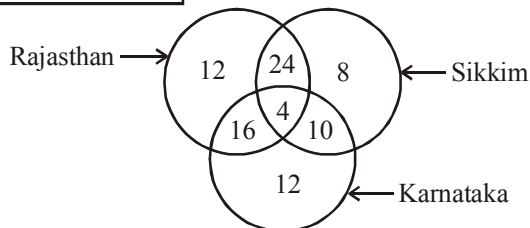
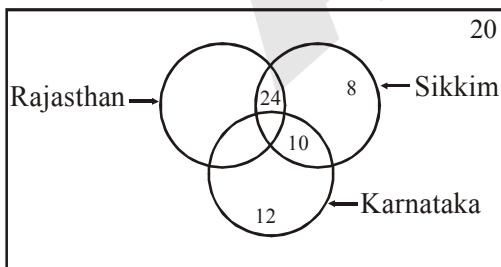

SOLUTION
NATIONAL TALENT SEARCH EXAMINATION 2015 Stage-2
MENTAL ABILITY TEST (MAT)

48. How many tourists have visited at least two states ?

- (1) 46 (2) 50 (3) 54 (4) 58

Sol. (3) 54 tourists have visited at least two states.

49. How many tourists have visited only two states?

- (1) 46 (2) 50 (3) 54 (4) 96

Sol. (2) 50 tourists have visited only two states.

50. Ifg BREAKTHROUGH is coded as EAOUHRBRGHKT, then DISTRIBUTION will be coded as

- (1) STTIBUDIONRI (2) TISTBUONDIRI
(3) STTIBUONRIDI (4) RISTTIBUDION

Sol. (1) Acc. to letters positions.

* * * * *

SOLUTION
NATIONAL TALENT SEARCH EXAMINATION 2015 Stage-2
LANGUAGE COMPREHENSIVE TEST (LCT)

Q.1-5

Read the following passage and answer the questions given after it.

The loudest public food fight right now is about GMOs, or genetically modified organisms. Scientists add genes to corn, soya beans and other plants, usually to protect the crops from insects or herbicides. Those who support this say that the genetic help makes crops easier to grow and cheaper. But many consumers and those who keep an eye on food-safety worry that GMOs pose an unnatural threat to our health and the environment. These opponents say the GMOs have been linked to depression, allergies and even cancer. Unless we have been eating food labelled 100 percent organic – which means that it must be GMO-free—we probably have GMOs in our body system already!

1. Adding genes to crops will

- (1) Help in better crop-research. (2) Make them resistant to insect attacks.
(3) Make the foods 'organic'. (4) Give them a stable price in the markets.

Ans. (2)

Sol. It is written in second line of passage that scientists add genes to protect the crops from insects.

2. The “.....loudest public food fight” suggests that

- (1) People do not like the Crop Scientists.
(2) Crop Scientists are almost fighting in the streets.
(3) There is a great competition in growing GMOs.
(4) There are strong protests against GMOs

Ans. (4)

Sol. Last lines of passage making it clear that people are still against of GMO food.

3. Those who support GMOs say that

- (1) Growing the crops poses many challenges now.
(2) They do not protect the fields from insect-attacks.
(3) They bring down the prices of the crops.
(4) They help in carrying out more experiments with better results.

Ans. (3)

Sol. This answer is clear from the line, 'Those who support this say that the genetic help makes crops easier to grow and cheaper'.

4. Those who are opposed to GMOs say that

- (1) The costs of the crops will not change much in the markets.
(2) The pattern of growing and harvesting of crops will change.
(3) Such crop-research has been stopped.
(4) These crops can cause serious harm to our health.

Ans. (4)

Sol. This answer is from the line 'opponents say that GMOs pose an unnatural threat to our health'.

5. 'Organic foods' according to the passage are those are

- (1) already there in our bodies as GMOs (2) grown in well-organised farms
(3) grown free from GMOs (4) helpful to our body's various organs

Ans. (3)

Sol. In last line it is given that Organic food is grown free from GMOs.

6-10 Read the following passage and answer the questions given after it.

'We are living in the golden age of answer'. Of course information is not knowledge or wisdom, and data can mislead. Profusion of online information can be distracting or even useless. Privacy can also be a problem in a digital world where everything you've clicked can be used to sell things to you, evaluate you or embarrass you. Your iPhone or computer can provide information to others that you might prefer to keep to yourself. But revolutions always cause some damages. Things do get lost in the ocean of information. We no longer bother to remember stuff we can easily

SOLUTION
NATIONAL TALENT SEARCH EXAMINATION 2015 Stage-2
LANGUAGE COMPREHENSIVE TEST (LCT)

look up. We don't search for addresses as we use the GPS. We spend more time connecting with friends on Facebook than connecting with real friends. Still, pop-up ads, internet frauds and other inconveniences are a small price to pay for instant access to infinite information. Today we have better tools for searching, analysing or evaluating through data than before. And what's most exciting about our age of answers is, its potential to change the quality of our lives.

6. The passage primarily discusses
- (1) the advantage of technology (2) criticism of technology
(3) the age of technology (4) the evaluation of the pros and cons of technology

Ans. (4)

Sol. The whole para is describing the good and bad effect of technology.

7. 'The golden age of answers' implies that there are
- (1) diverse technologies available in the present time (2) opportunities to connect with friends on Facebook
(3) better tools for searching information (4) pop-up ads to provide information

Ans. (3)

Sol. Only ans (3) is giving an appropriate information about 'golden age'.

8. We pay a price for this revolution as we
- (1) only receive useless information (2) forget our identities
(3) get agitated (4) surrender our privacy

Ans. (4)

Sol. As information can be received from anywhere so it is clear that we have surrendered our privacy.

9. This 'revolution' has brought
- (1) radical changes to our lives. (2) success in our lives.
(3) rotation in our lives. (4) merely problems in our lives.

Ans. (1)

Sol. This is clear by the things which are explained that revolution has also caused some damages.

10. The author's attitude to technology according to this passage is
- (1) not clear. (2) positive. (3) negative. (4) insignificant.

Ans. (2)

Sol. Last line of author suggest that he has positive attitude towards technology.

Q. 11-15 Read the following passage and answer the questions given after it.

For Abid Surti, Sunday is no day of rest. He is busy going to door volunteering with an assistant and a plumber. They are in an apartment building in Mumbai's densely populated suburb filled with high rise buildings. He rings doorbells and asks residents the same question, 'Any leaky taps? We are providing a free service.'

Surti is a multifaceted 79 year old man. A national award winning author, he has written some 80 books – novels, plays and collection of short stories and poems. He is also an artist and a cartoonist. In 2007, Surti started Drop Dead Foundation, his won water conservation NGO that caters the buildings in Mira Road, fixing leaky plumbing for free. With water shortages and the prospects of taps running dry in Mumbai, Surti's work is vital. 'Massive' is how he describes water wastage in Mumbai. 'In poor families, they can't afford to pay a plumber but in most middle-class families, the problem is one of sheer indifference. 'Indeed it was the apathy of a friend that first spurred Surti into action. While visiting a friend's house, Surti saw a leaking tap and asked why it wasn't fixed. His friend casually dismissed the query, saying it was hard to get a plumber 'for something so trivial.'

11. Surti's primary mission is to
- (1) provide free plumbers. (2) check wastage of water (3) supply free water. (4) close running taps.

Ans. (2)

Sol. Whole passage is suggesting this thing that it is the main motive of Abid Surti to check the wastage of water.

SOLUTION
NATIONAL TALENT SEARCH EXAMINATION 2015 Stage-2
LANGUAGE COMPREHENSIVE TEST (LCT)

- 12.** People may be more willing to accept Surti's services as he
 (1) provides services assisted by a plumber. (2) runs a water conservation NGO.
 (3) is a local person from Mumbai. (4) is on a mission.

Ans. (1)

Sol. Surti's services are accepted because he provides services assisted by a plumber.

- 13.** Most middle-class families' attitude to water conservation is due to their
 (1) lack of knowledge. (2) lack of money. (3) lack of expertise. (4) lack of concern.

Ans. (4)

Sol. Poor families don't have money but middle class families attitude towards water problem is due to lack of concern.

- 14.** The work being done by Surti is significant because he
 (1) runs an NGO in Mumbai. (2) has several skills.
 (3) is providing plumbing services. (4) is solving social problems.

Ans. (4)

Sol. This work is significant because generally tape leakage is avoided due to not getting plumber for something so trivial. And Surti is doing social service by solving water problem.

- 15.** 'spurred into action' means
 (1) emboldened to act. (2) volunteered to act. (3) keen to act. (4) encouraged to act.

Ans. (4)

Sol. 'Spurred into action means' to encourage to act something.

Q. (16 to 17): The following five sentences come from a paragraph. The first and the last sentences are given. Choose the right order in which the three sentences (PQR) should appear to complete the paragraph.

- 16.** S 1. Normally ladybugs are sophisticated and voracious predators.
 S 2. _____
 S 3. _____
 S 4. _____

S 5. Then it creeps up and strikes, ripping the victim apart with its barbed mandibles.

P – Once it has homed in on these signals, it switches its sensory scan to search for molecules released by the victim.

Q – A single individual may devour several thousands of victims in a lifetime.

R – to find a victim, it first waves its antennae to detect chemicals that plants release when they are under attack by herbivorous insects.

Choose from the options given below :

- (1) RPQ (2) PRQ (3) QRP (4) PQR

Ans. (3)

Sol. S1 is giving information about ladybugs and 'Q' is giving information what a ladybug can do, so answer will be 'QRP'.

- 17.** S 1. Years ago, the kids were all keen on 'soda water powder', soft drink mix that made carbonated beverages.
 S 2. _____
 S 3. _____
 S 4. _____

S 5. They began calling them Popsicles instead, and the treat was patented as such.

P – Epperson cleverly sat on his invention, keeping it secret for 18 years, until he was in the position to make something of it.

SOLUTION
NATIONAL TALENT SEARCH EXAMINATION 2015 Stage-2
LANGUAGE COMPREHENSIVE TEST (LCT)

Q – One night in 1905, Frank Epperson accidentally left his drink out on the porch, and as it froze overnight, it was absolutely delicious by the morning.

R – In 1923, he decided to patent his Epsicles (“Epp’s Icicles”), but his children refused to use that name since none of them called their father Epp.

Choose from the options given below :

- (1) PRQ (2) RPQ (3) RQP (4) QPR

Ans. (4)

Sol. ‘Q’ is linking with S1 because it is providing information how soda water was invented.

Q. (18-19) : The following questions have the second sentence missing. Choose the appropriate sentence from the given option to complete it.

- 18.** A. I used to think that boiling an egg would be a simple job until I came to live in the Himalayas.
B. _____
C. I don’t know if it’s the altitude or the density of the water, but it just won’t come to a boil in time for break fast.
1.
2.
(1) I found that just getting the water to boil was an achievement.
(2) Boiling an egg in the Himalayas was fascinating.
(3) I could never find good eggs there.
(4) “Were the eggs also too hard?” I wondered.

Ans. (1)

Sol. ‘A’ is linked with ‘1’ because it says that author came to know about difficulty of boiling egg when he came to live in the Himalayas.

- 19.** A. Imagine a five-year old composing music and playing on a child-size violin.
B. _____
C. He was a young genius who grew up to be one of the most creative composers of all time.
(1) This was something Mozart did. (2) It is strange to find such a phenomenon.
(3) The child must have been some genius. (4) This is simply impossible for us to think of

Ans. (1)

Sol. Answer is decided by ‘C’ as it has ‘He’ and he will be used for some person that is given in Answer ‘1’

Q. (20 – 29) : Choose the word which best fills the blank from the four options given,

- 20.** The journey in the run down bus over the pot-holed road felt almost like a ride.
(1) train (2) boat (3) roller-coaster (4) bicycle

Ans. (3)

Sol. Run down bus is giving hint. Because ‘roller coaster’ also gives the same feeling when it comes down.

- 21.** The good old Ambassador cars are now considered
(1) obsolete (2) absolute (3) obscure (4) oblivious

Ans. (1)

Sol. ‘Obsolete’ means no longer produced or out of date.

- 22.** The report has been prepared well and hopefully it will be at the next board meeting.
(1) shelved (2) chaired (3) tabled (4) grounded

Ans. (3)

Sol. Tabled at means to lay (the topic) on the table for consideration.

- 23.** The Talent Search Examination is challenging but not frightening. Why don’t you take a at it ?
(1) shot (2) trial (3) hit (4) swipe

Ans. (1)

Sol. ‘Take a shot’ means to try to do something.

SOLUTION
NATIONAL TALENT SEARCH EXAMINATION 2015 Stage-2
LANGUAGE COMPREHENSIVE TEST (LCT)

24. Grandfather has always been a figure of in our large family.

- (1) authorised (2) authoritative (3) authoritarian (4) authority

Ans. (4)

Sol. 'Authority' word is noun that is most suitable after 'figure of'

25. She found Rashmi in the kitchen, looking old and

- (1) healthy (2) weary (3) busy (4) in a hurry

Ans. (2)

Sol. 'Old and weary' both will come together as she was working in kitchen and she was looking rather 'tired (weary)'.

26. Tax offenders were refused to leave the country.

- (1) admission (2) submission (3) information (4) permission

Ans. (4)

Sol. admission, submission, information can not be answer. As 'permission' is needed to leave the country.

27. A good driver will be very careful before carrying out a complex

- (1) movement (2) manoeuvre (3) motion (4) moment

Ans. (2)

Sol. 'manoeuvre' means a movement or series of moves requiring skill and care.

28. With the new Management taking over, there's now a big hanging over the Company's future.

- (1) thought (2) gossip (3) discussion (4) question mark

Ans. (4)

Sol. New management taking over, so it is a 'big question mark' now on company's future.

29. The Coffee Room was into smoking and non-smoking areas.

- (1) amalgamated (2) considered (3) segregated (4) shared

Ans. (3)

Sol. Coffee room was divided in two areas and 'segregated' means also 'to divide'.

Q.(30-35) : Select the meaning of the given phrases/idioms.

30. For want of

- (1) because of lack of (2) giving something wanted by another
(3) desiring something (4) because of fulfilling needs

Ans. (1)

Sol. 'for want of' means 'because of lack of something/resources'.

31. Clown around

- (1) make others feel silly and stupid (2) be an object of ridicule
(3) join a Circus company (4) behave in a silly way

Ans. (4)

Sol. 'Clown around' means 'behave in a funny or silly way'.

32. Talk back

- (1) answer rudely (2) talk behind a person's back
(3) talk in a loud voice (4) reply to the questions asked

Ans. (1)

Sol. 'Talk back' means 'Reply rudely or defiantly'.

SOLUTION
NATIONAL TALENT SEARCH EXAMINATION 2015 Stage-2
LANGUAGE COMPREHENSIVE TEST (LCT)

- 33.** Run into
(1) meet someone by chance (2) start quarrelling
(3) make unexpected purchases (4) run from one place to another

Ans. (1)

Sol. 'Run into' Idiom means 'Collide with' or 'To meet or find someone or something by chance'.

- 34.** blow one's own trumpet
(1) to create music (2) to praise someone (3) to praise oneself (4) to feel happy

Ans. (3)

Sol. 'Blow one's own trumpet' means 'to boast or praise oneself greatly'.

- 35.** To see eye to eye
(1) stare at someone (2) examine someone's eyes
(3) have the same opinion (4) be cross-eyed

Ans. (3)

Sol. 'To see eye to eye' means 'To be able to come to an agreement' or 'have the same opinion'.

Q.36-43

In the following passage there are some numbered blanks. Fill in the blanks by selecting the most appropriate word for each blank from the given option.

At Sri Venkateswara Temple in Tirumala, better known as Tirupati, the laddu is next in popularity only to the Lord. The taste and aroma of (36) besan (gram flour) confections – saturated (37) ghee, raisin, nuts, cardamon, and (38) camphor – draws millions of devotees (39) this temple town in Andhra Pradesh, (40) for a bite of this holy (41) In 2009, it received international (42) when its was given the unique global (43) i.e. legal protection against imitation.

- 36.** (1) this (2) these (3) those (4) their

Ans. (2)

Sol. here 'laddus' are mentioned so 'these' is used.

- 37.** (1) from (2) of (3) in (4) with

Ans. (4)

Sol. 'saturated' word takes 'with' preposition with it.

- 38.** (1) edible (2) fine (3) light (4) pious

Ans. (1)

Sol. the other things mentioned before this are edible and 'camphor' which is used in these laddus is also 'edible'.

- 39.** (1) with (2) to (3) for (4) from

Ans. (2)

Sol. devotees come 'to' this temple.

- 40.** (1) seen (2) look (3) eager (4) find

Ans. (3)

Sol. All people remain 'eager' for a bite.

- 41.** (1) dish (2) eat (3) taste (4) joy

Ans. (1)

Sol. 'This holy' is referring to 'dish of laddus'.

- 42.** (1) taste (2) fame (3) claim (4) love

Ans. (2)

Sol. These laddus have got international 'fame'.

SOLUTION
NATIONAL TALENT SEARCH EXAMINATION 2015 Stage-2
LANGUAGE COMPREHENSIVE TEST (LCT)

43. (1) index (2) quality (3) patent (4) reward

Ans. (3)

Sol. it was given a 'patent'.

Q.44-47

Select the most appropriate option to fill in the blanks from the given alternatives.

44. Located close to Charminar, the kilometer-long stretch of Laad Bazaar is with shops selling bright in every hue and colour.

(1) came (2) discovered (3) covered (4) filled

Ans. (4)

Sol. Laad bazaar in 'filled with' shops.

45. I suggest you should yourself with the rules before you join the meeting.

(1) familiar (2) familiarize (3) familiarly (4) familiarity

Ans. (2)

Sol. We need a verb after 'you should' so 'familiarize' is the only answer.

46. The child held the bag as tightly as if it were her most possession.

(1) prize (2) prizy (3) prized (4) prizely

Ans. (3)

Sol. 'prized' past participle verb is needed here.

47. The weakness in their defense has already cost them this season.

(1) dear (2) dearly (3) deary (4) dearness

Ans. (2)

Sol. 'dearly' adverb is describing verb 'cost'.

Q.48-50

Select the word which means the opposite of the given word.

48. Undertake

(1) recognise (2) being (3) refuse (4) rejoice

Ans. (3)

Sol. 'undertake' means 'promise to do something' and opposite of this will be 'refuse'.

49. Hefty

(1) half-hearted (2) light (3) heavy (4) halved

Ans. (2)

Sol. 'Hefty' means 'large and heavy' and opposite of this will be 'light'.

50. Miniature

(1) manicure (2) massive (3) missive (4) masculine

Ans. (2)

Sol. 'Miniature' means 'very small' and opposite will be 'Massive (very huge)'.

* * * * *

SOLUTION
NATIONAL TALENT SEARCH EXAMINATION 2015 Stage-2
SCHOLASTIC APTITUDE TEST (SAT)

1. A segment of DNA contains 1200 nucleotides, of which 200 have adenine base. How many cytosine bases are present in this segment of DNA?
(1) 100 (2) 200 (3) 400 (4) 800

Ans. (3)

Sol. In DNA adenine forms double hydrogen bond with thymine and cytosine form triple hydrogen bond with guanine. So, if adenine are 200 in number, thymine will be 200 also and hence cytosine and guanine will be 400 each out of 1200.

2. You are observing a non-chlorophyllous, eukaryotic organism with chitinous cell wall under a microscope. You shall describe the organism as a
(1) fungus (2) alga (3) protozoas (4) bacterium

Ans. (1)

Sol. Fungus have eukaryotic cells with chitinous cell wall. It shows heterotrophic mode of nutrition because of absence of chlorophyll.

3. Match the items given in column A and Column B, and identify the correct alternative listed below.

Column-A

Column-B

- | | |
|------------------------|------------------------|
| (a) Flying fish | (i) <i>Draco</i> |
| (b) Flying lizard | (ii) <i>Echidna</i> |
| (c) Egg laying mammals | (iii) <i>Exocoetus</i> |
| (d) Flightless bird | (iv) <i>Struthio</i> |

(1) (a)–(i), (b)–(iii), (c)–(ii), (d)–(iv)

(2) (a)–(iii), (b)–(i), (c)–(ii), (d)–(iv)

(3) (a)–(iii), (b)–(i), (c)–(iv), (d)–(ii)

(4) (a)–(i), (b)–(iii), (c)–(iv), (d)–(ii)

Ans. (2)

Sol. Flying fish – Exocoetus
Flying lizard – Draco
Egg laying mammal – Echidna
Flightless bird – Struthio

4. Which one of the following statements about cell organelles and their function is correct?

- (1) Mitochondria are associated with anaerobic respiration.
(2) Smooth endoplasmic reticulum is involved in protein synthesis.
(3) Lysosomes are important in membrane biogenesis.
(4) Golgi bodies are involved in packaging and dispatching of materials.

Ans. (4)

Sol. Golgi body is involved in packaging and dispatching of materials.

5. A leguminous plant grown in an autoclaved, sterilized soil fails to produce root nodules because–

- (1) autoclaved soil is not good for root growth. (2) autoclaved soil is devoid of bacteria.
(3) autoclaving reduces N_2 content of soil. (4) plants cannot form root hairs in such a soil.

Ans. (2)

Sol. When soil is autoclaved and sterilized, it leads to death of microorganisms (rhizobium bacteria). When leguminous plant is grown in this soil it fail to produce nodules due to absence of rhizobium bacteria.

6. The causative agent of the disease ‘sleeping sickness’ in human beings is an

- (1) intracellular parasite found in RBC (2) extracellular parasite found in blood plasma.
(3) intracellular parasite found in WBC. (4) extracellular parasite found on the surface of platelets

Ans. (2)

Sol. Causative agent of the disease “sleeping sickness” in human being is a protozoan, Trypanosoma specie which is an extracellular parasite found in blood plasma.

SOLUTION
NATIONAL TALENT SEARCH EXAMINATION 2015 Stage-2
SCHOLASTIC APTITUDE TEST (SAT)

7. The gene of hemophilia is present on X chromosome. If a hemophilic male marries a normal female, the probability of their son being hemophilic is
(1) nil (2) 25% (3) 50% (4) 100%

Ans. (1)

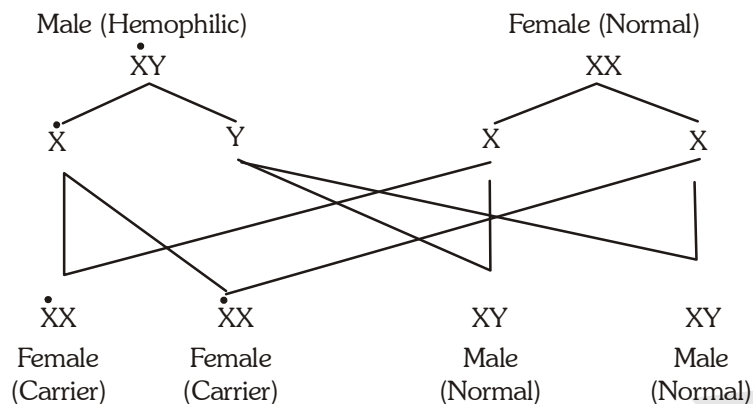

Sol.

8. Abundance of coliform bacteria in a water body is indicative of pollution from
(1) petroleum refinery (2) metal smelter
(3) fertilizer factory (4) domestic sewage

Ans. (4)

Sol. Domestic sewage contains faecal matter, having coliform bacteria (eg. *E. coli*). If a water body is having coliform bacteria, it is indication of pollution from domestic sewage.

9. Prolonged exposure to the fumes released by incomplete combustion of coal may cause death of a human because of—
(1) inhalation of unburnt carbon particles (2) continuous exposure to high temperature
(3) increased level of carbon monoxide (4) increased level of carbon dioxide

Ans. (3)

Sol. Incomplete combustion of coal produces carbon monoxide which is highly toxic and cause death of human.

10. The phenomenon of normal breathing in a human being comprises
(1) an active inspiratory and a passive expiratory phase
(2) a passive inspiratory and an active expiratory phase
(3) both active inspiratory and expiratory phases
(4) both passive inspiratory and expiratory phases

Ans. (1)

Sol. Inspiration during breathing is done by contraction of muscles of ribs and diaphragm, so it is a active process. While during expiration or exhalation muscles of ribs and diaphragm relaxes. So it is passive process.

11. Which one of the following statements is true with respect to photosynthesis?
(1) Oxygen evolved during photosynthesis comes from CO₂.
(2) Chlorophyll a is the only photosynthetic pigment in plants.
(3) Photosynthesis occurs in stem of some plants.
(4) Photosynthesis does not occur in red light.

Ans. (3)

Sol. Stems of some plants adapted for photosynthesis having chlorophyll in their cells.

SOLUTION
NATIONAL TALENT SEARCH EXAMINATION 2015 Stage-2
SCHOLASTIC APTITUDE TEST (SAT)

- 12.** The girth of stem increases due to the activity of
 (1) lateral meristem (2) apical meristem
 (3) intercalary meristem (4) apical and intercalary meristem

Ans. (1)

Sol. Girth / diameter of plants stem increases due to activity of lateral meristem.

- 13.** Which one of the following represents the correct sequence of reflex action?
 (1) Receptor → Sensory nerve → motor nerve → spinal cord → muscle
 (2) Receptor → motor nerve → spinal cord → sensory nerve → muscle
 (3) Receptor → sensory nerve → spinal cord → muscle → motor nerve
 (4) Receptor → sensory nerve → spinal cord → motor nerve → muscle

Ans. (4)

Sol. Correct sequence of path of reflex action is.

Receptor → sensory nerve → spinal cord → motor nerve → muscle or effector.

- 14.** In human female, immature eggs are for the first time seen in ovary
 (1) at puberty (2) before birth, at the fetus stage
 (3) during the first menstrual cycle (4) after the first year of birth

Ans. (2)

Sol. In human female, egg development starts at fetus stage. So immature eggs are first seen in ovary before birth at foetus stage.

- 15.** What happens when a fixed amount of oxygen gas is taken in a cylinder and compressed at constant temperature?
 (a) Number of collisions of oxygen molecules at per unit area of the wall of the cylinder increase.
 (b) Oxygen (O₂) gets converted into ozone (O₃).
 (c) Kinetic energy of the molecules of oxygen gas increases.
 (1) a and c (2) b and c (3) c only (4) a only

Ans. (4)

Sol. With the increase in pressure the number of collision increases as their is decrease in volume (at constant temp.)

- 16.** The solubility of a substance S in water is 28.6% (mass by volume) at 50°C. When 50 mL of its saturated solution at 50°C is cooled to 40°C, 2.4 g of solid S separates out. The solubility of S in water at 40°C (mass by volume) is:
 (1) 2.4% (2) 11.9% (3) 26.2% (4) 23.8%

Ans. (4)

Sol. 100 ml of solution contains — 28.6 g of solute

50 ml of solution contains — 14.3 g of solute

& 2.4 g solute separates when the solution is cooled from 50° to 40°C.

So, solute left in solution = 11.9 g (14.3 - 2.4) in 50 ml

$$\text{So, } \frac{m}{V} \% = \frac{11.9}{50} \times 100 = 23.8\%$$

- 17.** What mass of CO₂ will be formed when 6 g of carbon is burnt in 32 g of oxygen?
 (1) 38 g (2) 12 g (3) 26 g (4) 22 g

Ans. (4)

Sol. C + O₂ → CO₂

so, molar ratio is 1 : 1 : 1 and $\frac{1}{2}$ mole $\left(\frac{6}{12}\right)$ of carbon is given,

so CO₂ formed will also be $\frac{1}{2}$ mole and mass will be 22 g.

SOLUTION
NATIONAL TALENT SEARCH EXAMINATION 2015 Stage-2
SCHOLASTIC APTITUDE TEST (SAT)

18. The law of conservation of mass is valid for which of the following ?

(a) Reactions involving oxidation.

(b) Nuclear reactions.

(c) Endothermic reactions.

(1) a and c

(2) a and b

(3) b and c

(4) b only

Ans. (1)

Sol. Reactions involving oxidation and Endothermic reactions involves only change in energy, keeping the mass constant. Thus following the law of mass conservation.

19. How many sub-atomic particles are present in an α -particles used in Rutherford's scattering experiment ?

No. of Protons No. of Neutrons No. of Electrons

(1) 4 0 0

(2) 2 0 2

(3) 2 2 0

(4) 2 2 1

Ans. (3)

Sol. α -particles is Helium nucleus (He^{2+})

so, no. of protons = 2

no. of electrons = 0

no. of neutrons = 2

20. A certain sample of element Z contains 60% of ^{69}Z and 40% ^{71}Z . What is the relative atomic mass of element Z in this sample ?

(1) 69.2

(2) 69.8

(3) 70.0

(4) 70.2

Ans. (2)

Sol. Average atomic mass = $\frac{\% \text{ of first isotope} \times \text{mass of first isotope} + \% \text{ of second isotope} \times \text{mass of second isotope}}{100}$

$$\frac{60 \times 69 + 40 \times 71}{100} = 69.8 = \text{avg. atomic mass}$$

21. Compound A on strong heating in a boiling tube gives off reddish brown fumes and a yellow residue with a few drops of sodium hydroxide solution, a white precipitate appeared. Identify the cation and anion present in the compound A.

(1) Copper (II) and nitrate

(2) Lead (II) and chloride

(3) Zinc and sulphate

(4) Lead (II) and nitrate

Ans. (4)

Sol. Compound A is Lead (II) Nitrate.

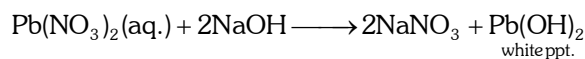

so, the ions are Lead (II) and Nitrate.

22. A substance A reacts with another substance B to produce the product C and a gas D. If a mixture of the gas D and ammonia is passed through an aqueous solution of C, baking soda is formed. The substances A and B are

(1) HCl and NaOH

(2) HCl and Na_2CO_3

(3) Na and HCl

(4) Na_2CO_3 and H_2O

SOLUTION
NATIONAL TALENT SEARCH EXAMINATION 2015 Stage-2
SCHOLASTIC APTITUDE TEST (SAT)

Ans. (2)

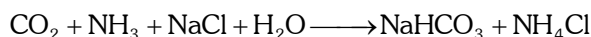
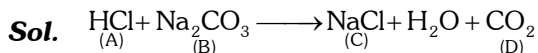

23. A metal occurs in nature as its ore X which on heating in air converts to Y. Y reacts with unreacted X to give the metal. The metal is

- (1) Hg (2) Cu (3) Zn (4) Fe

Ans. (2)

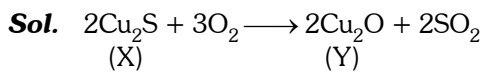

Copper glance Cuprous oxide

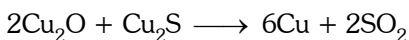

24. Assertion (A) : Nitrate ores are rarely available.

Reason (R) : Bond dissociation energy of nitrogen is very high.

- (1) Both A and R are true and R is the correct explanation of A.
(2) Both A and R are correct but R is not the correct explanation of A.
(3) A is correct and R is false.
(4) Both A and R are false.

Ans. (1)

Sol. The bond dissociation energy of N_2 is high because of the presence of triple bond which requires high amount of energy to get broken.

25. The number of structural isomers of the compound having molecular formula $\text{C}_4\text{H}_9\text{Br}$ is

- (1) 3 (2) 5 (3) 4 (4) 2

Ans. (3)

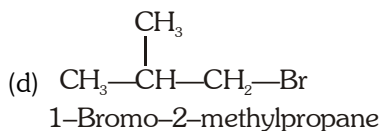
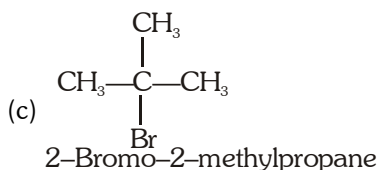
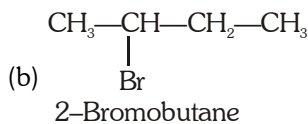
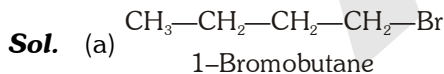

26. The total number of electrons and the number of electrons involved in the formation of various bonds present in one molecule of propanal ($\text{C}_2\text{H}_5\text{CHO}$) are respectively.

- (1) 32 and 20 (2) 24 and 20 (3) 24 and 18 (4) 32 and 18

SOLUTION
 NATIONAL TALENT SEARCH EXAMINATION 2015 Stage-2
SCHOLASTIC APTITUDE TEST (SAT)

Ans. (1)

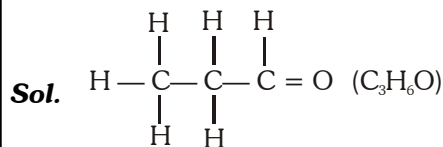

Total no. of electrons are $3 \times 6 + 6 \times 1 + 1 \times 8 = 32$

Total no. of bonds are 10 and each bond contains $2e^-$

SO total e^- involved in bonding = $10 \times 2 = 20$

27. Consider following as a portion of the periodic table from Group No. 13 to 17. Which of the following statement/s is/are true about the elements shown in it ?

- (I) V, W, Y and Z are less electropositive than X.
 (II) V, W, X and Y are more electronegative than Z.
 (III) Atomic size of Y is greater than that of W.
 (IV) Atomic size of W is smaller than that of X.

			V	Z
W				Y
X				

- (1) I, II and III (2) II and III (3) I and IV (4) III and IV

Ans. (3)

Sol. W = Al, X = In, V = O, Z = F, Y = Cl

- (I) Down the group electropositivity increases and along the period from left to right electropositive character decreases. So X is most electropositive.
 (II) Z = Flourine is the most electronegative element.
 (III) Along a period (left to right) size decreases because of increase in nuclear charge. So $W > Y$ (atomic size).
 (IV) Down the group size increases as the no. of shell increases. So $W < X$.

28. A man running with a uniform speed 'u' on a straight road observes a stationary bus at a distance 'd' ahead of him. At that instant, the bus starts with an acceleration 'a'. The condition that he would be able to catch the bus is :

- (1) $d \leq \frac{u^2}{a}$ (2) $d \leq \frac{u^2}{2a}$ (3) $d \leq \frac{u^2}{3a}$ (4) $d \leq \frac{u^2}{4a}$

Ans. (2)

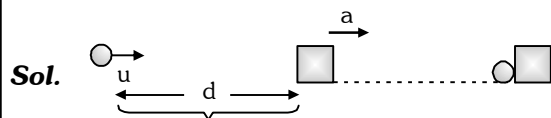

Velocity of bus after 't' time

$$v = at$$

Velocity of bus should be less than the velocity of man when they meet

$$u > at$$

SOLUTION
 NATIONAL TALENT SEARCH EXAMINATION 2015 Stage-2
SCHOLASTIC APTITUDE TEST (SAT)

$$t < \frac{u}{a}$$

distance travelled by bus = distance by man

$$d + \frac{1}{2}at^2 = ut$$

$$t \leq \frac{u}{a}$$

$$d = ut - \frac{1}{2}at^2$$

$$d \leq u \times \frac{u}{a} - \frac{1}{2} \times \frac{u^2}{a^2}$$

$$d \leq \frac{u^2}{a} - \frac{u^2}{2a}$$

$$d \leq \frac{u^2}{2a}$$

- 29.** A ball is thrown vertically upwards with a given velocity 'v' such that it rises for T seconds ($T > 1$). What is the distance traversed by the ball during the last one second of ascent (in meters) ? (Acceleration due to gravity is $g \text{ m/s}^2$).

(1) $\frac{1}{2}gT^2$

(2) $vT + \frac{1}{2}g[T^2 - (T-1)^2]$

(3) $\frac{g}{2}$

(4) $\frac{1}{2}g[T^2 - (T-1)^2]$

Ans. (3)

Sol. Distance travelled in last one second of ascent is equal to the distance travelled in first one second of descent.

Distance travelled in one second of descent

$$S = \frac{1}{2} \times g(1)^2 = \frac{g}{2}$$

Distance travelled in last second = $\frac{g}{2}$

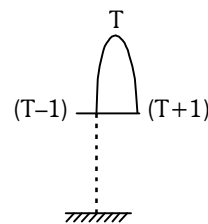

- 30.** The radius of a planet A is twice that of planet B. The average density of the material of planet A is thrice that of planet B. The ratio between the values of acceleration due to gravity on the surface of planet A and that on the surface of planet B is :

(1) $\frac{2}{3}$

(2) $\frac{3}{2}$

(3) $\frac{4}{3}$

(4) 6

Ans. (4)

Sol. $r_A = 2r_B$
 $d_A = 3d_B$

$$a_A = \frac{GM}{r_A^2} = \frac{Gd_A \times \frac{4}{3}\pi r_A^3}{r_A^2} = Gd_A \frac{4}{3}\pi r_A$$

SOLUTION
NATIONAL TALENT SEARCH EXAMINATION 2015 Stage-2
SCHOLASTIC APTITUDE TEST (SAT)

$$a_B = \frac{GM}{r_B^2} = \frac{Gd_B \times \frac{4}{3} \pi r_B^3}{r_B^2} = Gd_B \frac{4}{3} \pi r_B$$

$$\frac{a_A}{a_B} = \frac{Gd_A \times \frac{4}{3} \pi r_A}{Gd_B \times \frac{4}{3} \pi r_B} = \frac{d_A}{d_B} \times \frac{r_A}{r_B}$$

$$\frac{a_A}{a_B} = 3 \times 2 \Rightarrow \frac{a_A}{a_B} = 6$$

31. A small spherical ball of mass 'm' is used as the bob of a pendulum. The work done by the force of tension on its displacement is W_1 . The same ball is made to roll on a frictionless table. The work done by the force of normal reaction is W_2 . Again the same ball is given a positive charge 'q' and made to travel with a velocity v in a magnetic field B. The work done by the force experienced by the charged ball is W_3 . If the displacements in each case are the same, we have

(1) $W_1 < W_2 < W_3$

(2) $W_1 > W_2 > W_3$

(3) $W_1 = W_2 = W_3$

(4) that W_1, W_2, W_3 cannot be related by any equation

Ans. (3)

Sol. In all the 3 cases force is perpendicular to displacement so work done = 0

So all the forces are equal

$$W_1 = W_2 = W_3$$

32. The variation in the kinetic energy (K.E.) and the potential energy (P.E.) of a particle moving along the x-axis are shown in the graphs below. Which one of the following graphs violates the law of conservation of energy?

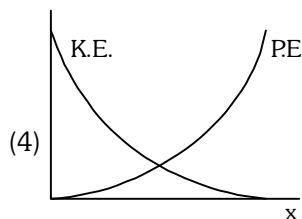
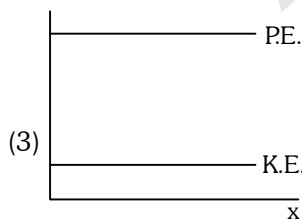
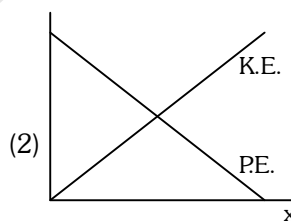
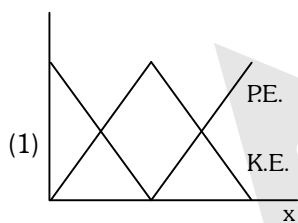

Ans. (4)

Sol. For the conservation of energy at all position $K.E. + P.E. = \text{constant}$ in fourth graph rate of decrease of K.E. is not equal to rate of increase of P.E. So it violates the law of conservation.

SOLUTION
 NATIONAL TALENT SEARCH EXAMINATION 2015 Stage-2
SCHOLASTIC APTITUDE TEST (SAT)

- 33.** The disc of a siren containing 60 holes rotates at a constant speed of 360 rotations per minute. The emitted sound is in unison with a tuning fork of frequency :
- (1) 270 Hz (2) 360 Hz (3) 480 Hz (4) 540 Hz

Ans. (2)

Sol. Number of holes in the disk determines the number of waves produced on each rotation. The total no. of waves (or puffs) per second determines the frequency of the sound.
 So frequency = 360 Hz

- 34.** A tuning fork is excited by striking it with a padded hammer. What would be the nature of the vibrations executed by the prongs as well as the stem of the fork respectively ? (The reference direction is that of the propagation of the sound wave.)
- (1) Both vibrate longitudinally
 (2) Both vibrate transversely
 (3) The prongs vibrate longitudinally whereas the stem vibrates transversely
 (4) The prong vibrate transversely whereas the stem vibrates longitudinally

Ans. (3)

Sol.

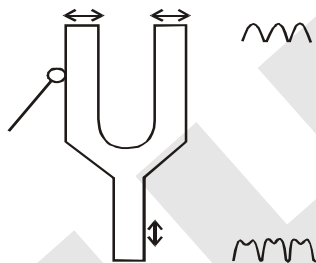

The prongs vibrate longitudinally whereas the stem vibrates transversely from reference direction of propagation of the sound wave.

- 35.** Find the reading of the ammeter in the circuit given below:

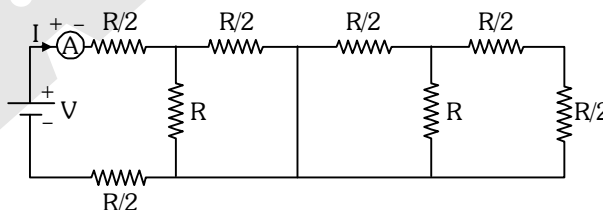

- (1) $\frac{V}{2R}$ (2) $\frac{3V}{4R}$ (3) $\frac{2V}{7R}$ (4) $\frac{11V}{R}$

Ans. (2)

Sol. At point a and b circuit is short circuited.

So $R_{eq} = \frac{R}{2} + R \parallel \left(\frac{R}{2} + \frac{R}{2} \right)$

SOLUTION
 NATIONAL TALENT SEARCH EXAMINATION 2015 Stage-2
SCHOLASTIC APTITUDE TEST (SAT)

$$= \frac{R}{2} + \frac{R \times \frac{R}{2}}{R + \frac{R}{2}} + \frac{R}{2}$$

$$= R + \frac{\frac{R^2}{2}}{\frac{3R}{2}} = R + \frac{R}{3} = \frac{4R}{3}$$

$$= R + \frac{\frac{R}{2}}{\frac{3R}{2}} = R + \frac{R}{3} = \frac{4R}{3}$$

$$I = \frac{V}{R_{eq}} = \frac{V}{\frac{4R}{3}} = \frac{3V}{4R}$$

- 36.** Three bulbs with individual power ratings of 12W, 2W and 6W respectively are connected as per the circuit diagram below. Find the amount of heat dissipated by each in 10 seconds.

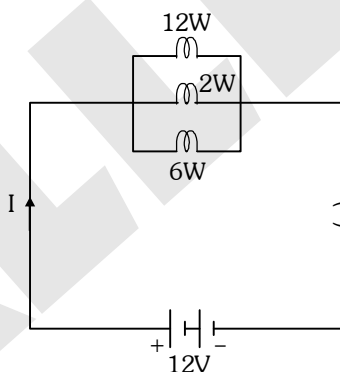

- (1) 8J, 1.33J, 4J (2) 120J, 20J, 60J (3) 10J, 0.277J, 2.5J (4) 12J, 1.66J, 5J

Ans. (2)

Sol. Heat dissipated by each bulb in 10 seconds

$$H = P \times t$$

$$H_1 = 12W \times 10 \text{ sec.} = 120J$$

$$H_2 = 2W \times 10 \text{ sec.} = 20J$$

$$H_3 = 6W \times 10 \text{ sec.} = 60J$$

- 37.** Which of the following can produce a magnetic field ?

- (1) Electric charges at rest (2) Electric charges in motion
 (3) Only by permanent magnets (4) Electric charges whether at rest or in motion

Ans. (2)

Sol. Magnetic field is produced by moving charge.

SOLUTION
NATIONAL TALENT SEARCH EXAMINATION 2015 Stage-2
SCHOLASTIC APTITUDE TEST (SAT)

- 38.** A wire is lying horizontally in the north-south direction and there is a horizontal magnetic field pointing towards the east. Some positive charges in the wire move north and an equal number of negative charges move south. The direction of force on the wire will be :

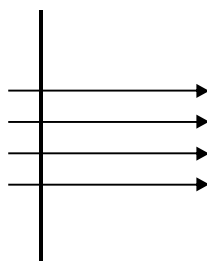

- (1) east (2) down, into the page (3) up, out of the page (4) west

Ans. (2)

Sol. By using Fleming's left hand rule direction of force is down, into the page.

- 39.** Match the following :

Phenomenon	Reason
(i) Rainbow	A. Scattering of light
(ii) Twinkling of stars	B. Dispersion of light
(iii) Blue colour of sky	C. Fluctuation of the refraction index in atmosphere layers
(iv) Advancement of sunrise and delay of sunset	D. Refraction of light

(1) (i)-B, (ii)-D, (iii)-A, (iv)-C

(2) (i)-B, (ii)-C, (iii)-A, (iv)-D

(3) (i)-B, (ii)-A, (iii)-C, (iv)-D

(4) (i)-D, (ii)-B, (iii)-A, (iv)-C

Ans. (2)

Sol. Rainbow → Dispersion of light
 Twinkling → Fluctuation of the refractive index
 Blue colour of sky → Scattering of light
 Advancement of sunrise and delay sunset → Refraction of light

- 40.** A person is suffering from both near sightedness and far sightedness. His spectacles would be made of
- two convex lenses with the upper lens having a larger focal length than the lower lens.
 - two concave lenses with the upper lens having a smaller focal length than the lower lens.
 - a concave lens as the upper lens and a convex lens as the lower lens
 - a convex lens as the upper lens and a concave lens as the lower lens

Ans. (1)

Sol. Upper part of spectacles used for viewing long distance object so concave lens is used while lower part is used for reading books so convex lens is used.

- 41.** LCM of two numbers x and y is 720 and the LCM of numbers $12x$ and $5y$ is also 720. The number y is
- (1) 180 (2) 144 (3) 120 (4) 90

Ans. (2)

SOLUTION
NATIONAL TALENT SEARCH EXAMINATION 2015 Stage-2
SCHOLASTIC APTITUDE TEST (SAT)

Sol. $12x = 2^2 \times 3^1 \times x$

$5y = 5 \times y$

$720 = 2^4 \times 3^2 \times 5^1$

i.e. y is not a multiple of 5.

Clearly y is 144.

42. When a natural number x is divided by 5, the remainder is 2. When a natural number y is divided by 5, the remainder is 4. The remainder is z when x + y is divided by 5. The value of $\frac{2z-5}{3}$ is

(1) -1

(2) 1

(3) -2

(4) 2

Ans. (1)

Sol. $x = 5m + 2$

$y = 5n + 4$

$\therefore x + y = 5(m + n) + 6$
 $= 5(m + n + 1) + 1$

But given that when x + y is divided by 5 remainder is z

$\therefore z = 1$

Now, $\frac{2z-5}{3} = \frac{2 \times 1 - 5}{3} = -1$

43. If the zeroes of the polynomial $64x^3 - 144x^2 + 92x - 15$ are in A.P., then the difference between the largest and the smallest zeroes of the polynomial is

(1) 1

(2) $\frac{7}{8}$

(3) $\frac{3}{4}$

(4) $\frac{1}{2}$

Ans. (1)

Sol. Let zeroes are

$a - d, a, a + d.$

so $3a = \frac{144}{64} \Rightarrow a = \frac{48}{64} = \frac{3}{4}$

$a(a^2 - d^2) = \frac{15}{64}$

$\frac{3}{4} \left(\frac{9}{16} - d^2 \right) = \frac{15}{64}$

$\frac{9}{16} - d^2 = \frac{5}{16}$

$d^2 = \frac{4}{16} \Rightarrow d = \pm \frac{1}{2}$

So zeroes are

$\frac{3}{4} - \frac{1}{2}, \frac{3}{4}, \frac{3}{4} + \frac{1}{2}$

SOLUTION
NATIONAL TALENT SEARCH EXAMINATION 2015 Stage-2
SCHOLASTIC APTITUDE TEST (SAT)

$$\Rightarrow \frac{1}{4}, \frac{3}{4}, \frac{5}{4}$$

$$\text{difference } \frac{5}{4} - \frac{1}{4} = \frac{4}{4} = 1$$

44. x and y are two non-negative numbers such that $2x + y = 10$. The sum of the maximum and minimum values of $(x + y)$ is

- (1) 6 (2) 9 (3) 10 (4) 15

Ans. (4)

Sol. $2x + y = 10$

So, $2x + y + y = 10 + y$

$2(x + y) = 10 + y$

$$x + y = 5 + \frac{y}{2}$$

So, $(x + y)_{\max}$ when y is maximum & maximum value of y will be 10.

So $(x + y)_{\max} = 5 + 5 = 10$

& $(x + y)_{\min}$ when $y = 0$

$(x + y)_{\min} = 5$

So, sum of $(x + y)_{\max}$ & $(x + y)_{\min} = 15$

45. The number of integral solutions of the equation $7\left(y + \frac{1}{y}\right) - 2\left(y^2 + \frac{1}{y^2}\right) = 9$ is

- (1) 0 (2) 1 (3) 2 (4) 3

Ans. (2)

Sol. $7\left(y + \frac{1}{y}\right) - 2\left(y^2 + \frac{1}{y^2}\right) - 9 = 0$

$$7\left(y + \frac{1}{y}\right) - 2\left(y + \frac{1}{y}\right)^2 + 4 - 9 = 0$$

$$2\left(y + \frac{1}{y}\right)^2 - 7\left(y + \frac{1}{y}\right) + 5 = 0$$

Let $y + \frac{1}{y} = a$

$\Rightarrow 2a^2 - 7a + 5 = 0$

$\Rightarrow 2a^2 - 5a - 2a + 5 = 0$

$\Rightarrow a(2a - 5) - 1(2a - 5) = 0$

$\Rightarrow (2a - 5)(a - 1) = 0$

SOLUTION
NATIONAL TALENT SEARCH EXAMINATION 2015 Stage-2
SCHOLASTIC APTITUDE TEST (SAT)

i.e. $a = \frac{5}{2}, a = 1$

Now, $y + \frac{1}{y} = \frac{5}{2}$

$$2y^2 - 5y + 2 = 0$$

$$2y^2 - 4y - y + 2 = 0$$

$$2y(y - 2) - 1(y - 2) = 0$$

$$(y - 2)(2y - 1) = 0$$

$$y = 2, y = \frac{1}{2}$$

So $y = 2$ is only integral solution

$$y + \frac{1}{y} = 1$$

$$y^2 - y + 1 = 0$$

$$y = \frac{1 \pm \sqrt{1 - 4 \times 1 \times 1}}{2 \times 1}$$

y is unreal.

- 46.** A circle with area $A \text{ cm}^2$ is contained in the interior of a larger circle with area $(A + B) \text{ cm}^2$ and the radius of the larger circle is 4 cm. If $A, B, A+B$ are in arithmetic progression, then the diameter (in cm) of the smaller circle is

(1) $\frac{\sqrt{3}}{2}$

(2) $\frac{4\sqrt{3}}{3}$

(3) $\frac{8\sqrt{3}}{3}$

(4) $2\sqrt{3}$

Ans. (3)

Sol. Let the radius of the smaller circle is r

$$\therefore A = \pi r^2$$

$$A + B = 16\pi \Rightarrow B = 16\pi - \pi r^2$$

Given that $A, B, A+B$ are in A.P.

$$(A) + (A + B) = 2B$$

$$\Rightarrow B = 2A$$

$$\Rightarrow 16\pi - \pi r^2 = 2\pi r^2$$

$$\Rightarrow r^2 = \frac{16}{3}$$

$$\Rightarrow r = \frac{4\sqrt{3}}{3} \Rightarrow D = \frac{8\sqrt{3}}{3}$$

- 47.** Each of the sides of a triangle is 8 cm less than the sum of its other two sides. Area of the triangle (in cm^2) is

(1) 8

(2) $8\sqrt{3}$

(3) 16

(4) $16\sqrt{3}$

Ans. (4)

Sol. Given that the sides are x, y, z

$$x + y - 8 = z$$

$$y + z - 8 = x$$

$$x + z - 8 = y$$

solving equation $x = y = z = 8$

$$\text{Area} = \frac{\sqrt{3}}{4} \times 8^2 = 16\sqrt{3}$$

SOLUTION
 NATIONAL TALENT SEARCH EXAMINATION 2015 Stage-2
SCHOLASTIC APTITUDE TEST (SAT)

48. If $\operatorname{cosec} x - \cot x = \frac{1}{3}$, where $x \neq 0$, then the value of $\cos^2 x - \sin^2 x$ is

- (1) $\frac{16}{25}$ (2) $\frac{9}{25}$ (3) $\frac{8}{25}$ (4) $\frac{7}{25}$

Ans. (4)

Sol. $\operatorname{cosec} x - \cot x = \frac{1}{3}$

$\therefore \operatorname{cosec} x + \cot x = 3$

Solving $\operatorname{cosec} x = \frac{10}{6}$

$\sin x = \frac{3}{5}$

$\Rightarrow \cos x = \frac{4}{5}$

$\therefore \cos^2 x - \sin^2 x = \frac{7}{25}$

49. A sector with acute central angle θ is cut from a circle of diameter 14 cm. The area (in cm^2) of the circle circumscribing the sector is

- (1) $\frac{22}{7} \sec^2 \frac{\theta}{2}$ (2) $\frac{77}{2} \sec^2 \theta$
 (3) $\frac{7}{2} \cos^2 \frac{\theta}{2}$ (4) $\frac{77}{2} \sec^2 \frac{\theta}{2}$

Ans. (4)

Sol. Now $\cos \frac{\theta}{2} = \frac{7}{2 \times r}$

$r = \frac{7}{2} \sec \frac{\theta}{2}$

Area of circle = πr^2

$= \frac{22}{7} \times \frac{49}{4} \times \sec^2 \frac{\theta}{2}$

$= \frac{77}{2} \sec^2 \frac{\theta}{2}$

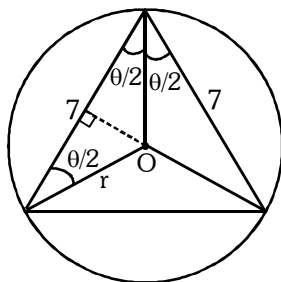

SOLUTION
 NATIONAL TALENT SEARCH EXAMINATION 2015 Stage-2
SCHOLASTIC APTITUDE TEST (SAT)

50. In the figure, PQSO is a trapezium in which $PQ \parallel OS$, $\angle POS = 135^\circ$ and $\angle OSQ = 90^\circ$. Points P, Q and R lie on a circle with centre O and radius 12 cm. The area of the shaded part, in cm^2 , is

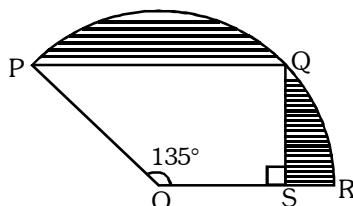

(1) $61\frac{2}{7}$

(2) $61\frac{5}{7}$

(3) $73\frac{5}{7}$

(4) $73\frac{2}{7}$

Ans. (2)

Sol. $QS = OS = 6\sqrt{2}$ and $PQ = 12\sqrt{2}$

Area of shaded region

$$= \frac{135^\circ}{360^\circ} \times \pi \times (12)^2 - \frac{1}{2} \times 18\sqrt{2} \times 6\sqrt{2}$$

$$= \frac{3\pi \times 144}{8} - 108$$

$$= 61\frac{5}{7} \text{ cm}^2$$

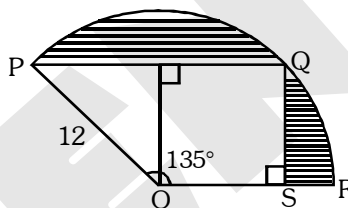

51. A solid sphere is cut into identical pieces by three mutually perpendicular planes passing through its centre. Increase in total surface area of all the pieces with respect to the total surface area of the original sphere is
 (1) 250% (2) 175% (3) 150% (4) 125%

Ans. (3)

Sol. Three mutually perpendicular planes will cut sphere into eight identical pieces.

Now one identical piece surface Area = $\frac{3}{4}\pi r^2 + \frac{\pi r^2}{2}$

Total new surface Area = $8 \times \frac{5}{4}\pi r^2 = 10\pi r^2$
 and original surface Area = $4\pi r^2$

Ratio % = $\frac{6\pi r^2}{4\pi r^2} \times 100\% = 150\%$

52. A right circular cylinder has its height equal to two times its radius. It is inscribed in a right circular cone having its diameter equal to 10 cm and height 12 cm, and the axes of both the cylinder and the cone coincide. Then, the volume (in cm^3) of the cylinder is approximately

(1) 107.5

(2) 118.6

(3) 127.5

(4) 128.7

Ans. (3)

SOLUTION
 NATIONAL TALENT SEARCH EXAMINATION 2015 Stage-2
SCHOLASTIC APTITUDE TEST (SAT)

Sol. Given $h = 2r$

$$\Delta PSC \sim \Delta AOC$$

$$\Rightarrow \frac{PS}{AO} = \frac{SC}{OC} = \frac{PC}{AC}$$

$$\Rightarrow \frac{h}{12} = \frac{5-r}{5} = \frac{PC}{AC}$$

$$\Rightarrow \frac{h}{12} = \frac{5-r}{5}$$

$$\Rightarrow 10r = 60 - 12r$$

$$\Rightarrow 22r = 60 \Rightarrow r = \frac{30}{11}$$

$$h = 2r \Rightarrow h = \frac{60}{11}$$

$$\text{volume} = \pi r^2 h$$

$$= \frac{22}{7} \times \frac{900}{121} \times \frac{60}{11} \approx 127.50$$

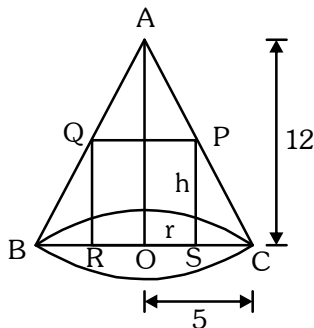

53. In the figure, ABCD is a square of side 1 dm and $\angle PAQ = 45^\circ$.
 The perimeter (in dm) of the triangle PQC is

- (1) 2 (2) $1 + \sqrt{2}$
 (3) $2\sqrt{2} - 1$ (4) $1 + \sqrt{3}$

Ans. (1)

Sol. Let $\angle DAQ = x^\circ$

$$\therefore \tan x = \frac{DQ}{AD}$$

$$\tan x = \frac{DQ}{1}$$

$$\therefore QC = 1 - DQ = 1 - \tan x$$

Now In ΔABP

$$\tan (45 - x) = \frac{BP}{1}$$

$$\frac{1 - \tan x}{1 + \tan x} = \frac{BP}{1}$$

$$\therefore PC = 1 - BP$$

$$= 1 - \left(\frac{1 - \tan x}{1 + \tan x} \right) = \frac{1 + \tan x - 1 + \tan x}{1 + \tan x}$$

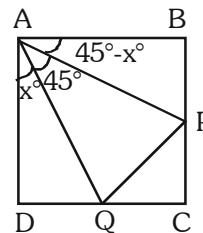

SOLUTION
 NATIONAL TALENT SEARCH EXAMINATION 2015 Stage-2
SCHOLASTIC APTITUDE TEST (SAT)

$$PC = \frac{2 \tan x}{1 + \tan x}$$

Now $PQ^2 = QC^2 + PC^2$

$$= (1 - \tan x)^2 + \frac{(2 \tan x)^2}{(1 + \tan x)^2}$$

$$PQ^2 = \frac{(1 - \tan^2 x)^2 + 4 \tan^2 x}{(1 + \tan x)^2} = \frac{(1 + \tan^2 x)^2}{(1 + \tan x)^2}$$

$$PQ = \frac{1 + \tan^2 x}{1 + \tan x}$$

Now Perimeter = $PQ + QC + PC$

$$= \frac{1 + \tan^2 x}{1 + \tan x} + 1 - \tan x + \frac{2 \tan x}{1 + \tan x}$$

$$\Rightarrow \frac{1 + \tan^2 x + 1 - \tan^2 x + 2 \tan x}{1 + \tan x} = \frac{2 + 2 \tan x}{1 + \tan x} = 2$$

54. In the figure, ABC is a triangle in which AD bisects $\angle A$, $AC = BC$, $\angle B = 72^\circ$ and $CD = 1$ cm. Length of BD (in cm) is

- (1) 1 (2) $\frac{1}{2}$
 (3) $\frac{\sqrt{5}-1}{2}$ (4) $\frac{\sqrt{3}+1}{2}$

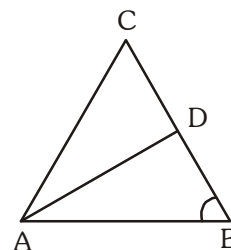

Ans. (3)

Sol. i.e. $AD = 1$ cm. ($AD = CD$)
 $AB = AD \Rightarrow AB = 1$ cm.

Now $\frac{AC}{AB} = \frac{CD}{BD}$

$$\Rightarrow \frac{1+x}{1} = \frac{1}{x}$$

$$\Rightarrow x + x^2 - 1 = 0$$

$$\Rightarrow x^2 + x - 1 = 0$$

$$x = \frac{-1 \pm \sqrt{(1)^2 - 4(1)(-1)}}{2} = \frac{-1 \pm \sqrt{5}}{2}$$

$$BD = \frac{\sqrt{5}-1}{2}$$

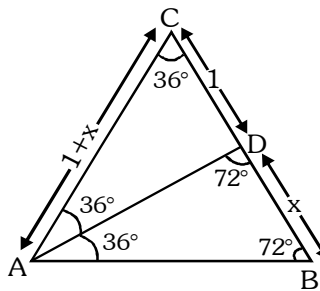

SOLUTION
 NATIONAL TALENT SEARCH EXAMINATION 2015 Stage-2
SCHOLASTIC APTITUDE TEST (SAT)

55. In the figure, BC is a chord of the circle with centre O and A is a point on the minor arc BC.

Then, $\angle BAC - \angle OBC$ is equal to

- (1) 30° (2) 60°
 (3) 80° (4) 90°

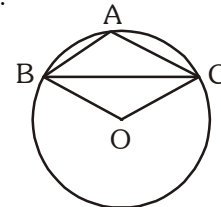

Ans. (4)

Sol. Let $\angle BOC = 2x$
 then $\angle BAC = 180^\circ - x$
 and $\angle OBC = 90^\circ - x$
 Now $\angle BAC - \angle OBC = 180^\circ - x - 90^\circ + x$
 $= 90^\circ$

56. In the figure, $\triangle APB$ is formed by three tangents to the circle with centre O. If $\angle APB = 40^\circ$, then the measure of $\angle BOA$ is

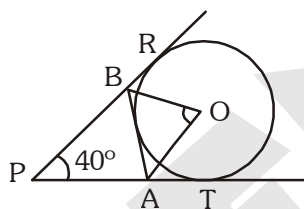

- (1) 50° (2) 55° (3) 60° (4) 70°

Ans. (4)

Sol.

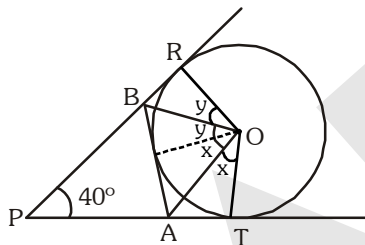

From figure $2x + 2y = 140^\circ$
 $\angle BOA = x + y = 70^\circ$

57. $(5, -10)$, $(-15, 15)$ and $(5, 5)$ are the coordinates of vertices A, B and C respectively of $\triangle ABC$ and P is a point on median AD such that $AP : PD = 2 : 3$. Ratio of the areas of the triangles PBC and ABC is

- (1) $2 : 3$ (2) $3 : 4$ (3) $3 : 5$ (4) $4 : 5$

Ans. (3)

Sol.

$$\frac{\Delta BPD}{\Delta BAD} = \frac{\Delta CPD}{\Delta CAD} = \frac{3}{5}$$

i.e. $\frac{\Delta BPC}{\Delta BAC} = \frac{3}{5}$

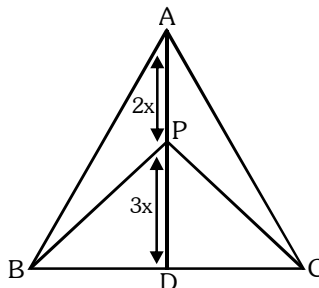

SOLUTION
NATIONAL TALENT SEARCH EXAMINATION 2015 Stage-2
SCHOLASTIC APTITUDE TEST (SAT)

58. P is a point on the graph of $y = 5x + 3$. The coordinates of a point Q are (3, -2). If M is the mid point of PQ, then M must lie on the line represented by

- (1) $y = 5x + 1$ (2) $y = 5x - 7$ (3) $y = \frac{5}{2}x - \frac{7}{2}$ (4) $y = \frac{5}{2}x + \frac{1}{2}$

Ans. (2)

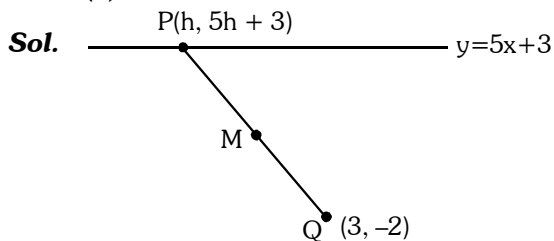

i.e. M is $\left(\frac{3+h}{2}, \frac{5h+1}{2}\right)$

Clearly M must lie on the line
 $y = 5x - 7$

59. Three - digit numbers formed by using digits 0, 1, 2 and 5 (without repetition) are written on different slips with distinct number on each slip, and put in a bowl. One slip is drawn at random from the bowl. The probability that the slip bears a number divisible by 5 is

- (1) $\frac{5}{9}$ (2) $\frac{4}{9}$ (3) $\frac{2}{3}$ (4) $\frac{1}{3}$

Ans. (1)

Sol. Total three digit numbers are : $3 \times 3 \times 2 = 18$
Now numbers divisible by 5 are : $2 \times 3 \times 1 + 2 \times 2 \times 1 = 10$
So probability is $= \frac{10}{18} = \frac{5}{9}$

60. The mean of fifteen different natural numbers is 13. The maximum value for the second largest of these numbers is
(1) 46 (2) 51 (3) 52 (4) 53

Ans. (2)

Sol. $x_1 + x_2 + x_3 + \dots + x_{15} = 15 \times 13 = 195$
to set the second largest and largest first thirteen natural numbers are
1, 2, 3, 4, 5, 6, 7, 8, 9, 10, 11, 12, 13
So $x_{14} + x_{15} = 195 - \frac{13 \times 14}{2}$
Now, $x_{14} = 51$ and $x_{15} = 53$ i.e. 51.

61. Assertion (A) : During eighteenth century France witnessed the emergence of a middle class.

Reason (R) : The emergence of the middle class happened on account of royal patronage.

- (1) A is true, R is false.
(2) A is false, R is true.
(3) Both A and R are true but R is not the correct explanation of A.
(4) Both A and R are true and R is the correct explanation of A.

SOLUTION
NATIONAL TALENT SEARCH EXAMINATION 2015 Stage-2
SCHOLASTIC APTITUDE TEST (SAT)

Ans. (1)

Sol. The emergence of the middle class happened because industrial revolution.

62. Assertion (A) : The lives of pastoralists in India underwent dramatic changes under colonial rule.

Reason (R) : In most areas the lands regularly used by pastoralists for grazing were taken over by the colonial state and given to select individuals for cultivation.

- (1) A is true, R is false
- (2) A is false, R is true
- (3) Both A and R are true but R is not the correct explanation of A.
- (4) Both A and R are true and R is the correction explanation of A.

Ans. (4)

Sol. In most areas the lands regularly used by pastoralists for grazing were taken over by the colonial state and given to select individuals for cultivation.

63. Assertion (A) : By the early twentieth century, America became the biggest supplier of wheat to Europe.

Reason (R) : The expansion of the railways during the period greatly facilitated the transport of grain.

- (1) A is true, R is false
- (2) A is false, R is true
- (3) Both A and R are true but R is not the correct explanation of A.
- (4) Both A and R are true and R is the correction explanation of A.

Ans. (4)

Sol. The spread of railways made it easy to, transport the grain from the wheat growing regions to the eastern coast for export.

64. Match the following table and choose the correct response from the options given thereafter.

Column-I

- A. 1910
- B. 1930
- C. 1907
- D. 1887

Column-II

- I. Establishment of Tonkin Free School.
- II. Formation of French Indo-China.
- III. Completion of the trans-Indo-China rail network.
- IV. Formation of the Vietnamese Communist Party.

- (1) A-III, B-IV, C-I, D-II
- (2) A-IV, B-III, C-II, D-I
- (3) A-III, B-I, C-IV, D-I
- (4) A-IV, B-I, C-II, D-III

Ans. (1)

65. Arrange the following Indian novels in accordance with their year of writing/publication

- a. Indulekha
- b. Rajasekhara Caritramu
- c. Yamuna Paryatan
- d. Pariksha-Guru

- (1) c, b, d, a
- (2) a, d, b, c
- (3) c, d, b, a
- (4) a, b, d, c

Ans. (1)

Sol.

- a. Indulekha published in → 1889
- b. Rajasekhara Caritramu published in → 1878
- c. Yamuna Paryatan published in → 1857
- d. Pariksha-Guru published in → 1882

66. The main tentes of April Theses during the Bolshevik Revolution were :

- (1) Closing the war, shifting of banks, land polling by government.
- (2) Formation of labour government, bank nationalisation and land distribution.
- (3) Communists government, land fragmentation and merger of banks.
- (4) Ending the war, bank nationalisation and land transfer.

SOLUTION
NATIONAL TALENT SEARCH EXAMINATION 2015 Stage-2
SCHOLASTIC APTITUDE TEST (SAT)

Ans. (4)

Sol. april thesis were three demands of Lenin
(1) Land to be transferred to the Peasants
(2) Bank be Nationalised
(3) World war first be brought to close.

67. Mahatma Gandhdi changed his dressing style from Western to Indian over a period of time. Match thsoe changes as givne Column-I and Column-II and choose the correct response from the option given thereafter

	Column-I		Column-II
A	Suit	I.	1915
B	Lungi-Kurta	II.	1890
C	Peasant Dress	III.	1921
D	Short Dhoti	IV.	1913

(1) A-II, B-IV, C-I, D-III
(3) A-III, B-IV, C-I, D-II

(2) A-II, B-I, C-IV, D-III
(4) A-IV, B-III, C-I, D-II

Ans. (1)

Sol.

- When Gandhiji went to London to study law as a boy of 19 in 1888, he dressed in a western suit.
- In Durban in 1913, Gandhiji first appeared in a lungi and kurta.
- On his return to India in 1915 he decided to dress like Kathiawadi peasants.
- Only in 1921 he adopted short dhoti.

68. In late 19th and early 20th centuries, nationalism captured the imagination of the Indian people through a variety of cultural processes. Which of the following was not a part of those processes ?

- (1) Rewriting history to show India's continuous progress from the ancient to the modern times.
- (2) Creation of different images of Bharat Mata.
- (3) Recording, collection and publication of folk tales and folk songs.
- (4) Designing flags as inspiring symbols of nationalism.

Ans. (1)

69. Choose the correct response from the given options.

Nomadic people move over long distances because

- (1) By temperament they do not like to settle down in any one place.
- (2) They constantly look for good pastureland for their cattle.
- (3) They follow a life style which is very different from the settled communities.
- (4) Economically they are too poor to own land.

Ans. (2)

70. Choose the correct response from the given options.

In 19th century England grain production grew as quickly as the population because

- (1) Farmers used simple agricultural technology to greater effect.
- (2) Radical innovations were made in agricultural technology.
- (3) Larger and larger areas were brought under cultivation.
- (4) Increasing number of poor people found work as agricultural labourers.

SOLUTION
NATIONAL TALENT SEARCH EXAMINATION 2015 Stage-2
SCHOLASTIC APTITUDE TEST (SAT)

Ans. (3)

Sol. In 19th century England grain production. This increase in food production was made possible not by any radical innovations in agricultural technology, but by bringing newlands under cultivation. They turned larger and larger areas into agricultural fields.

71. Choose the correct response from the given options.

By the late 19th century Indians began searching for a national dress because they wanted to

- (1) Show that in terms of dress they were not inferior to the British.
- (2) Get rid of the blame of blindly aping the West.
- (3) Define the cultural identity of the nation.
- (4) Cultuarlly synthesize the traditions of the East and the West.

Ans. (3)

Sol. By the late 19th century Indians began searching for a national dress because they wanted to define the cultural identity of the nation.

72. Choose the correct response from the given options.

The unification of Germany in 1871, for a change, demonstrated.

- (1) The triumph of the democractic aspirations of the German middle class.
- (2) The fulfilment of the liberal initiative to nation–building.
- (3) The power of the common people, das volk.
- (4) The dominance of the state power and conservatives success in mobilising nationalist sentiments.

Ans. (4)

Sol. The unification of Germany in 1871, for a change, demonstrated the dominance of the state power and conservatives success in mobilising nationalist sentiments.

73. Choose the correct response from the given options.

The formation of the ‘United Kingdom of Great Britain’ in 1707 meant, in effect.

- (1) Equal representation of all the British Isles in the British Parliament.
- (2) Recognition to the ethnic identities of the Welsh, the Scot and the Irish.
- (3) The cessation of conflicts between the Catholics and the Protestants.
- (4) The dominance of England on Scotland through the English supremacy in Parliament.

Ans. (4)

Sol. The dominance of England on Scotland through the English supremacy in Parliament.

74. Choose the correct response from the given option.

Many within the congress wre initially opposed to the idea of non-cooperation because–

- (1) They did not think that British rule in Indian would collapse if Indians refused to cooperate.
- (2) They were not yet sure of Gandhiji’s ability to successfully lead a nationwide movement.
- (3) They were reluctant to boycott the council election scheduled for November 1920.
- (4) They did not agree with Gandhiji’s proposal to carry the movement forward in stages.

Ans. (3)

Sol. Many within the congress wre initially opposed to the idea of non-cooperation because they were reluctant to boycott the council election scheduled for November 1920.

SOLUTION
NATIONAL TALENT SEARCH EXAMINATION 2015 Stage-2
SCHOLASTIC APTITUDE TEST (SAT)

- 75.** Choose the correct response from the given options.
The main reason why the society of Revolutionary and Republican Women was set up during the French Revolution was because.
- (1) women wanted laws that would help improve their lives.
 - (2) Women wanted the same political rights as men.
 - (3) Women wanted their interests to be properly represented in the new government.
 - (4) Women wanted access to education, training for jobs, and wages on par with men.

Ans. (2)

Sol. The main reason why the society of Revolutionary and Republican Women was set up during the French Revolution was because they wanted the same political rights as men.

- 76. Assertion (A) :** The El Nino, a cold ocean current flows along the coast of Peru during Christmas.
Reason (R) : The presence of the El Nino leads to an increase in sea-surface temperatures and weakening of the trade winds in the region.
- (1) Both A and R are true and R explains. A.
 - (2) Both A and R are true but R does not explain A.
 - (3) A is true and R is false.
 - (4) A is false and R is true.

Ans. (4)

Sol. The El Nino, a warm ocean current flows along the coast of Peru during Christmas.

- 77. Assertion (A) :** Air temperature decreases from the equator towards the poles.
Reason (R) : As one move from the sea level to higher altitudes, the atmosphere becomes less dense and temperature decreases.
- (1) Both A and R are true and R explains. A.
 - (2) Both A and R are true but R does not explain A.
 - (3) A is true and R is false.
 - (4) A is false and R is true.

Ans. (2)

Sol. Air temperature decreases from the equator towards the poles because of varying insolation. Insolation is different at different areas because of inclination of earth from its vertical axis.

- 78.** Match List-I (local name of shifting cultivation) with List-II (States/Region) and select the correct answer using the code given below:

List-I (Local name of shifting)

- A. Dahiya
- B. Kumari
- C. Bringa
- D. Kuruwa

List-II (States/Region)

- I. Jharkhand
- II. Madhya Pradesh
- III. Odisha
- IV. Western Ghats

- (1) A-III, B-IV, C-II, D-I (2) A-II, B-IV, C-III, D-I (3) A-I, B-III, C-IV, D-II (4) A-I, B-IV, C-III, D-II

Ans. (2)

- 79. Assertion (A) :** Most nuclear power stations in India have been constructed near sources of water.
Reason (R) : Nuclear power stations require a great quantity of water cooling purposes.

- (1) Both A and R are true and R explains A.
- (2) Both A and R are true but R does not explain A.
- (3) A is true and R is false
- (4) A is false and R is true

Ans. (1)

Sol. Nuclear power stations require a great quantity of water cooling purposes.

SOLUTION
NATIONAL TALENT SEARCH EXAMINATION 2015 Stage-2
SCHOLASTIC APTITUDE TEST (SAT)

80. Assertion (A) : Peninsular rocks contain many reserves of coal, metallic minerals, mica and many other non-metallic minerals.

Reason (R) : Sedimentary rocks on the western and eastern flanks of the peninsula, in Gujarat and Assam have most of the ferrous minerals.

- (1) Both A and R are true and R explains A.
(2) Both A and R are true but R does not explain A.
(3) A is true and R is false
(4) A is false and R is true

Ans. (3)

Sol. Ferrous minerals are found in igneous rocks.

81. Which one of the following states has common borders with the least number of countries ?

- (1) Uttarakhand (2) West Bengal (3) Arunachal Pradesh (4) Sikkim

Ans. (1)

82. Match List-I (Rivers) with List-II (National Waterways) and select the correct answer using the code given below:

List-I (Rivers)

- A. Ganga
B. Brahmaputra
C. Godavari and Krishan
D. Mahanadi and Brahmani

List-II (National Waterways)

- I. National Waterway No. 4
II. National Waterway No. 1
III. National Waterway No. 5
IV. National Waterway No. 2

- (1) A-I, B-II, C-III, D-IV (2) A-II, B-III, C-IV, D-I (3) A-IV, B-III, C-II, D-I (4) A-II, B-IV, C-I, D-III

Ans. (4)

83. Match List-I (Rivers) with List-II (Tributaries) and select the correct answer using the code given below:

List-I (Rivers)

- A. Godavari
B. Ganga
C. Krishna
D. Brahmaputra

List-II (Tributaries)

- I. Lihit
II. Koyana
III. Wainganga
IV. Son

- (1) A-II, B-III, C-IV, D-I (2) A-II, B-I, C-III, D-IV (3) A-III, B-IV, C-II, D-I (4) A-I, B-III, C-IV, D-II

Ans. (3)

84. Arrange these hills/ranges from north to south direction

- I. Zaskar Range
II. Shiwalik Range
III. Karakoram Range
IV. Ladakh Range

- (1) II, IV, I, II (2) III, I, IV, II (3) I, II, III, IV (4) IV, III, I, II

Ans. (1)

85. Match List-I (Rivers) with List-II (Origin) and select the correct answer using the codes given below:

List-I (Rivers)		List-II (origin)	
A.	Godavari	I.	Cardamom Hills
B.	Krishna	II.	Amarkantak Hills
C.	Narmada	III.	Nasik Hills
D.	Vaigai	IV.	Mahabaleshwar

- (1) A-IV, B-III, C-I, D-II (2) A-III, B-IV, C-II, D-I (3) A-I, B-II, C-IV, D-III (4) A-II, B-I, C-III, D-IV

Ans. (2)

SOLUTION
NATIONAL TALENT SEARCH EXAMINATION 2015 Stage-2
SCHOLASTIC APTITUDE TEST (SAT)

86. Assertion (A) : In India, most migrations have been from rural to urban areas.

Reason (R) : The urban areas offer greater employment opportunities and better living conditions.

- (1) Both A and R are true and R explains A (2) Both A and R are true but R does not explain A
 (3) A is true and R is false (4) A is true and R is false

Ans. (1)

Sol. Urban areas have more employment opportunities because of presence of industries and service sector units. Urban areas also have better living conditions because of the presence of numerous hospitals and educational institutions.

87. Arrange these hills from west to east direction

- A. Khasi hills B. Garo hills C. Naga hills D. Jaintia Range
 (1) C, A, B, D (2) D, B, A, C (3) A, B, C, D (4) B, A, D, C

Ans. (4)

88. Assertion (A) : The Earth does not receive an equal amount of solar energy at all latitudes.

Reason (R) : As one goes from low altitude to high altitude temperature decreases because atmosphere becomes less dense.

- (1) Both A and R are true and R explains A (2) Both A and R are true but R does not explain A
 (3) A is true and R is false (4) A is false and R is true

Ans. (2)

Sol. The Earth does not receive an equal amount of solar energy because of varied latitude, not because of altitude's position.

89. Match the vegetation zones in Column -I with the associated mean annual average temperature (in degree Celsius) in Column-II.

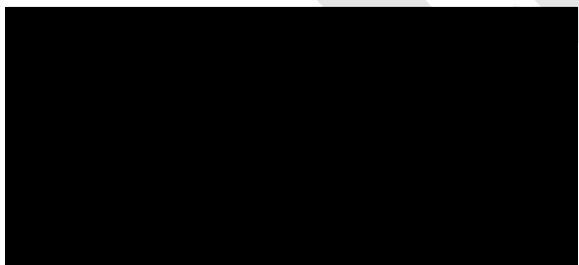

- (1) A-II, B-I, C-III, D-IV (2) A-II, B-III, C-IV, D-I (3) A-II, B-IV, C-III, D-I (4) A-IV, B-II, C-III, D-I

Ans. (1)

Sol.

Vegetation Zones	Mean annual Average Temp. (in degree C)	Mean Temp. in Jan. in degrees C	Remarks
Tropical	Above 24°C	Above 18°	No Frost
Sub-tropical	17°C to 24°C	10°C to 18°C	Frost is rare
Temperate	7°C to 17°C	-1°C to (-10) °C	Frost some snow
Alpine	Below 7°C	Below -1°C	Snow

SOLUTION
 NATIONAL TALENT SEARCH EXAMINATION 2015 Stage-2
SCHOLASTIC APTITUDE TEST (SAT)

90. Match the given crops with their major producing areas shown on the map of India.



- A. Wheat
- B. Coffee
- C. Rice
- D. Tea

(1) A-I, B-IV, C-III, D-II (2) A-I, B-II, C-III, D-IV (3) A-III, B-II, C-I, D-IV (4) A-IV, B-III, C-I, D-II

Ans. (2)

Sol. (I) Himachal Pradesh, Uttarakhand and Uttar Pradesh are important for the production of wheat
 (II) Coffee cultivation is confined to the Nilgiri in Karnataka, Kerala and Tamil Nadu.
 (III) In states like West Bengal and Odisha, three crops of paddy are grown in a year.
 (IV) Major tea producing states are Assam and hills of Darjeeling

91. Which of the following statement/s is/are true about federal system ?

- a. All federations have a similar scheme of distribution of powers.
- b. The origins of different federations are dissimilar.
- c. Federalism promotes unity at the cost of diversity.
- d. Federalism promotes unity in diversity.

(1) Only b (2) a and c (3) b and d (4) a, b and c

Ans. (3)

Sol. The origins of different federations are dissimilar as it is decided by historical, cultural and political conditions of a country. Federalism promotes unity in diversity as it gives the chance to different communities to lead the government in their majority areas.

92. I do not contest elections, but I try to influence the political process. I have a specific policy agenda. I have no interest in seeking political power. Who am I ?

- (1) Bureaucracy (2) Court (3) Pressure group (4) Media

Ans. (3)

Sol. Pressure groups are organisations that attempt to influence government policies. But unlike political parties, pressure groups do not aim to directly control or share political power.

93. Which of the following statements/s is/are true?

- a. India is among the bottom group of nations in the world when it comes to the representation of women in legislatures.
- b. Women in the Arab countries are most active in public life.
- c. India has lesser representation of women in legislatures as compared to Sub-Saharan Africa.
- d. The share of women in legislative assemblies in India is lower than that of their representation in Parliament.

(1) a and b (2) b and c (3) a, b and d (4) a, c and d

Ans. (4)

SOLUTION
 NATIONAL TALENT SEARCH EXAMINATION 2015 Stage-2
SCHOLASTIC APTITUDE TEST (SAT)

Sol. Women in national parliaments in different regions of the world (in%)

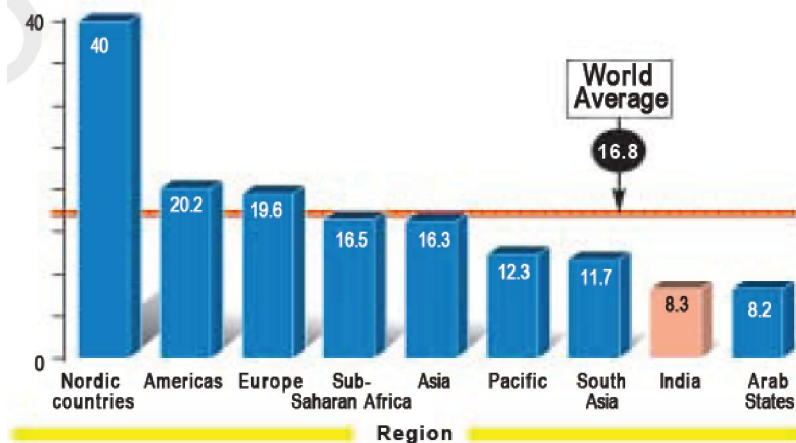

Note: Figures are for the per cent of women in the directly elected chambers of parliament in 2006
 Source: <http://www.ipu.org/wmn-e/world.htm>

94. Which of the following issues has been most successfully addressed by the Indian democracy?
 (1) Social inequality (2) Economic inequality (3) Political inequality (4) Natural inequality

Ans. (3)

Sol. Political inequality has been most successfully addressed by the Indian democracy as every adult has got voting rights in India.

95. Match List I (Leaders) with List II (Political parties) and select the answer using the codes given below.

	List I		List II
I.	E.M.S. Namboodiripad	a.	Bahujan Samaj Party
II.	Sheikh Abdullah	b.	Telugu Desam
III.	N.T. Rama Rao	c.	Communist Party of India (Marxist)
IV.	Kanshi Ram	d.	Jammu & Kashmir National Conference

- | | | | |
|--------|-----|------|-----|
| (1) Ic | IId | IIIa | IVb |
| (2) Ib | IId | IIIc | IVa |
| (3) Ib | IId | IIIa | IVd |
| (4) Ic | IId | IIIb | IVa |

Ans. (4)

Sol. I. E.M.S. Namboodiripad was Chief minister of Kerala who belonged to Communist Party of India (Marxist).
 II. Sheikh Abdullah was Chief minister of Jammu & Kashmir who belonged to Jammu & Kashmir National Conference.
 III. N.T. Rama Rao belonged to Telugu Desam Party.
 IV. Kanshi Ram was founder of Bahujan Samaj Party.

96. Economic growth is growth in
 (1) value of total output (2) value of total investment
 (3) value of industrial output (4) value added of all sectors

SOLUTION
NATIONAL TALENT SEARCH EXAMINATION 2015 Stage-2
SCHOLASTIC APTITUDE TEST (SAT)

Ans. (4)

Sol. G.D.P. is value of all final goods and services produced within the country.

97. Mahatma Gandhi National Rural Employment Guarantee Act aims at providing

- (1) employment to rural people in government offices.
- (2) 200 days of work/year in rural areas
- (3) 100 days of wage employment in a year to rural households
- (4) 365 days work in rural areas

Ans. (3)

Sol. Mahatma Gandhi National Rural Employment Guarantee Act aims at providing 100 days of wage employment in a year to rural households.

98. A landless worker in a village takes a king loan of two bags of rice from the village landlord. The condition is that she will repay the loan in two and half bags of rice at the end of one year. The interest paid equals

- (1) the difference between the money value of rice between now and at the end of the year.
- (2) 31.25 percent of the original amount of loan.
- (3) 25 percent of the original amount of loan.
- (4) the difference between the rates of interest charged by banks between now and at the end of the year.

Ans. (3)

Sol. Principal = 2 bags of Rice

$$\text{Amount} = 2\frac{1}{2} \text{ bags of Rice}$$

$$\text{Interest} = \text{Amount} - \text{Principal}$$

$$= \frac{1}{2} \text{ bags of Rice} = 25 \text{ percent of the original amount (two bags) of loan.}$$

99. Non-market activity is

- (1) a state of unemployment
- (2) producing for self consumption
- (3) selling the products nearby temples
- (4) selling the products through the Regulated Market

Ans. (2)

Sol. Self consumption is not a market activity.

100. A typical farmer's capital includes tractor, turbines, plough, seeds, fertilisers, pesticides and cash in hand. Which of these combinations can be classified as working capital?

- (1) Tractor, turbines and plough
- (2) Seeds, fertilisers, pesticides and cash in hand
- (3) Plough, seeds, fertilisers and pesticides
- (4) Plough, seeds, fertilisers, pesticides and cash in hand

Ans. (2)

Sol. Raw materials and money in hand are called **working capital**. Unlike tools, machines and buildings, these are used up in production.